

**PARTS LIST**
**Attachment Kit  
P/N 08V03-SZT-100A**

 Automatic day/night  
mirror harness

EPT sealer

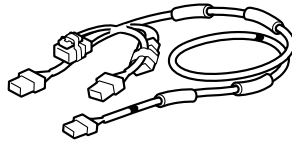
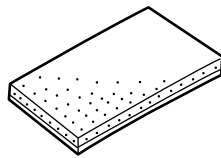

Clip



5 Wire ties

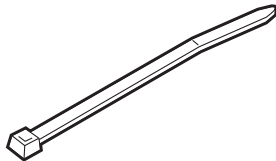

Fuse label

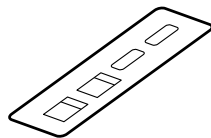

Harness cover

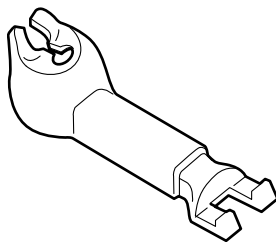
**Automatic Day/Night Mirror Kit  
P/N 08V03-TA0-100A**

Automatic day/night mirror

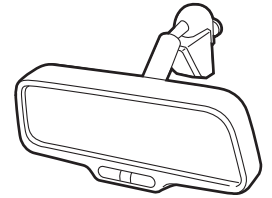

Spring

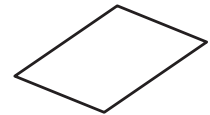

Operating Instructions

**TOOLS AND SUPPLIES REQUIRED**

Phillips screwdriver

Ratchet

8 mm and 10 mm Sockets

Isopropyl alcohol

Shop towel

Diagonal cutters

Needle nose pliers

10 mm Open end wrench

Rubber mallet

Trim Tool Set (T/N SOJATP2014)

(Available through the Honda Tool and Equipment program. On the iN, click on: Service/Service Bay/Tool and Equipment Program, then enter the number under "Search." Or call 888-424-6857.)

Flat-tip screwdriver

Masking tape

**Illustration of the Automatic Day/Night Mirror in the Vehicle**

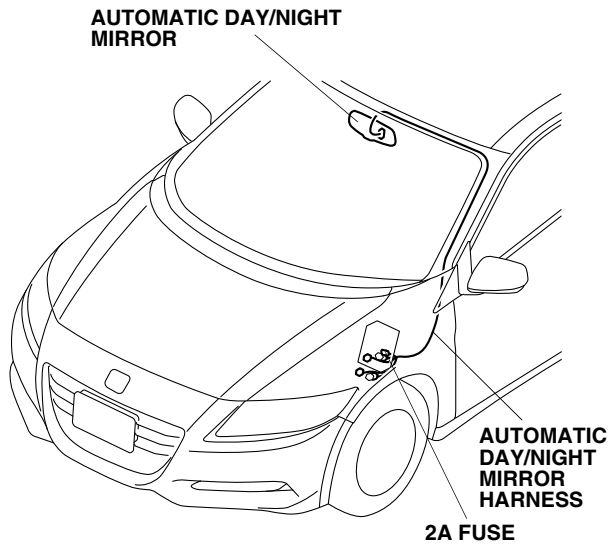

**INSTALLATION**

**Customer Information:** The information in this installation instruction is intended for use only by skilled technicians who have the proper tools, equipment, and training to correctly and safely add equipment to your vehicle. These procedures should not be attempted by "do-it-yourselfers."

1. Make sure you have the anti-theft codes for the audio unit and navigation system (if equipped), then write down the radio station presets.
2. Disconnect the negative cable from the battery.

3. Using a plastic trim tool, remove the left and right lenses from the map light console (four retaining tabs for each lens).

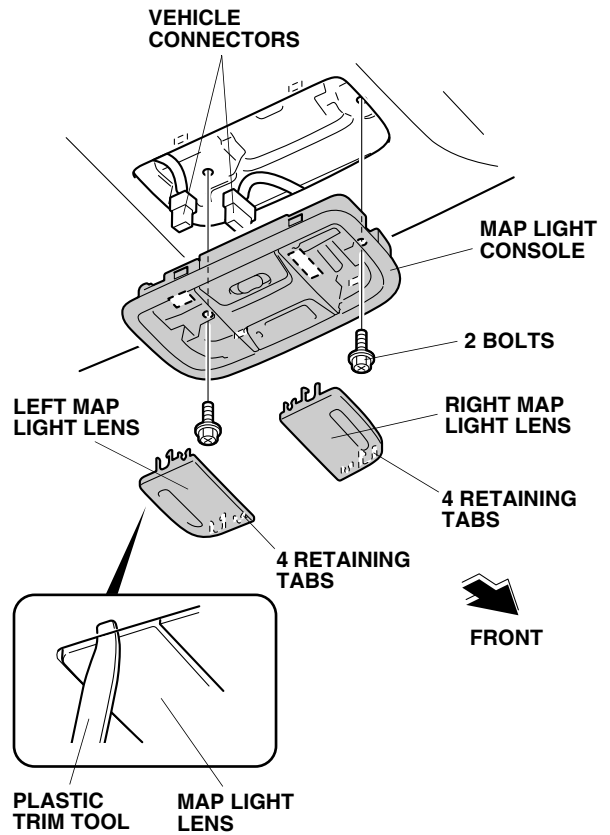

4. Remove the map light console (two bolts and unplug the vehicle connectors).
5. Remove the rearview mirror from the mirror holder by rotating the stay 90° clockwise.

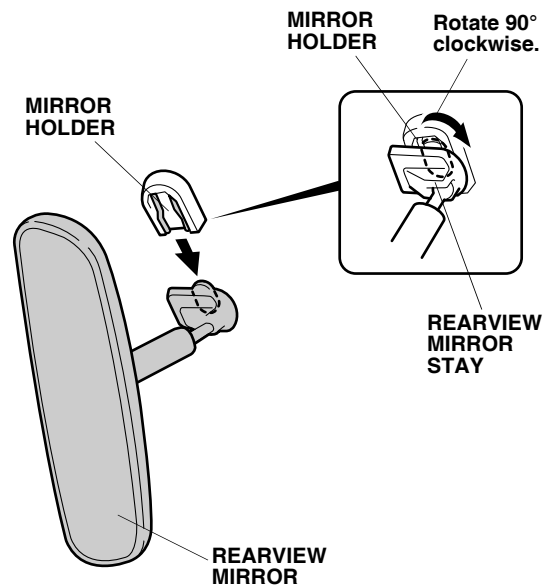

- Pivot down the left sunvisor and remove it from the holder.

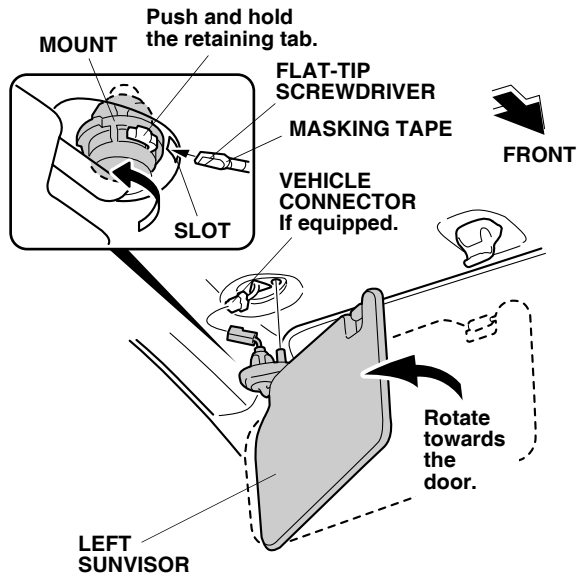

- Insert a flat-tip screwdriver wrapped with masking tape into the slot in the sunvisor mount. Push and hold the retaining tab.
- While holding the retaining tab, push up on the left sunvisor and rotate it towards the door to release the sunvisor. Then remove the left sunvisor.

NOTE: If the retaining tab did not stay pushed in, return the left sunvisor to its original position and repeat steps 7 and 8.

- Using a flat-tip screwdriver wrapped with masking tape, release the three retaining tabs on one side of the left sunvisor holder.

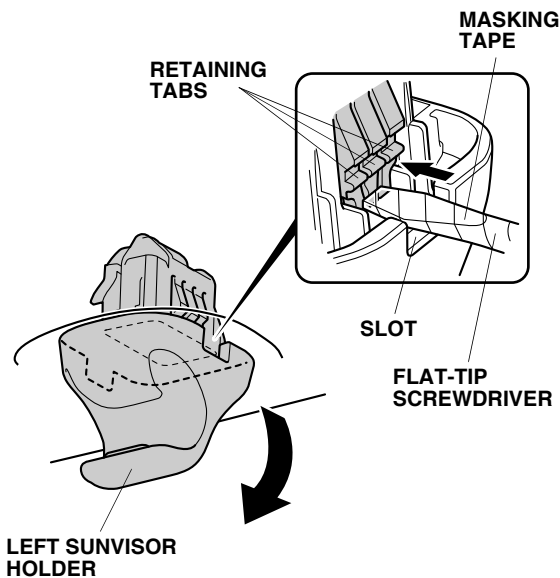

- Use a flat-tip screwdriver wrapped with masking tape to release the three retaining tabs on the other side of the left sunvisor holder. Remove the holder.

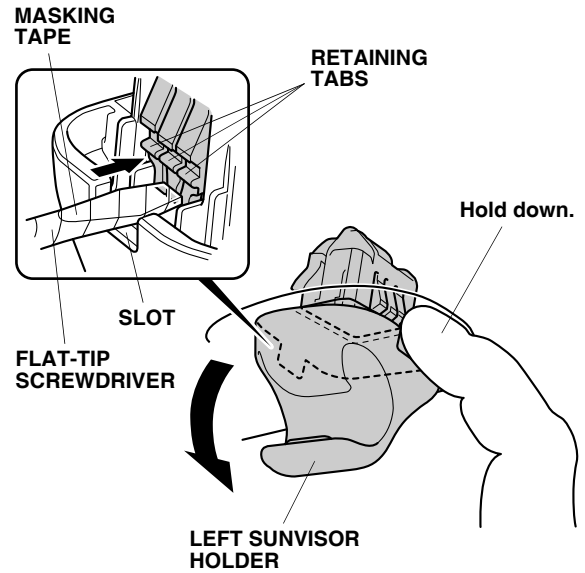

- Pull away the door seal from the driver's A-pillar trim.

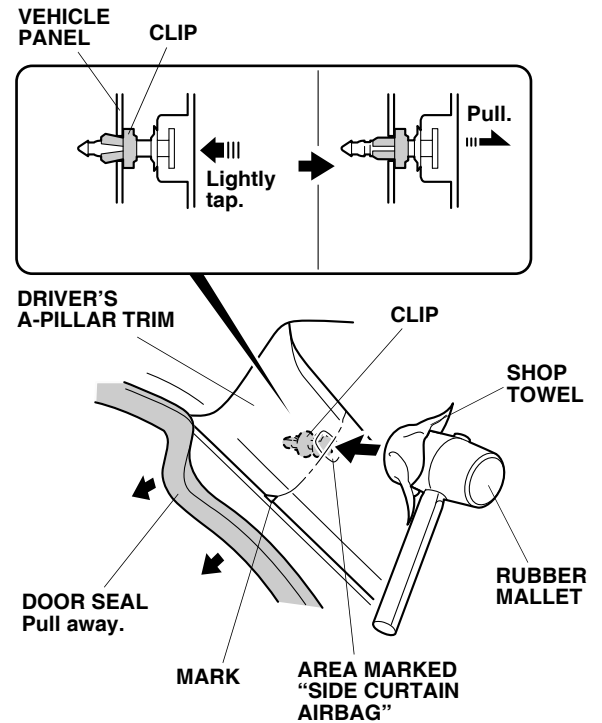

- Using a rubber mallet wrapped with a shop towel, tap lightly on the area marked "SIDE CURTAIN AIRBAG" on the driver's A-pillar trim to push in the clip. Make sure to tap perpendicular to the A-pillar surface.

13. Remove the driver's A-pillar trim (two clips).

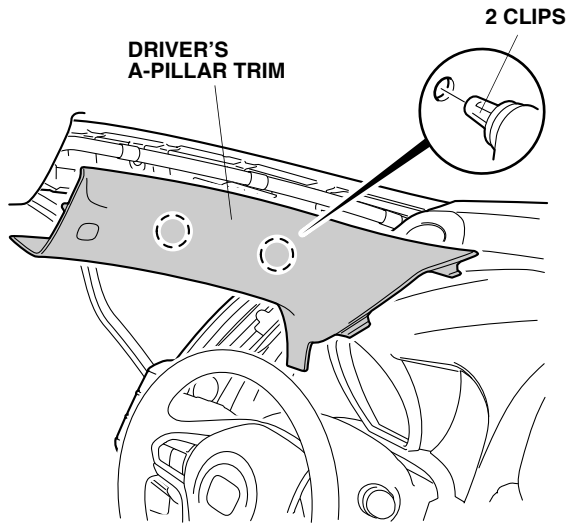

14. Remove the fuse box cover (four retaining tabs).

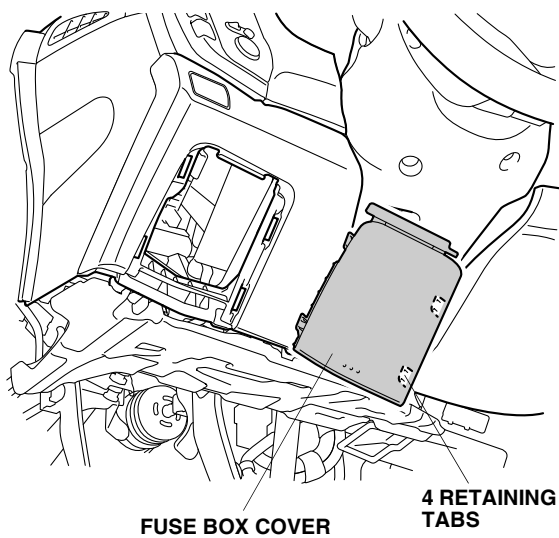

15. Remove the driver's under cover (one knob, two clips, and one pin).

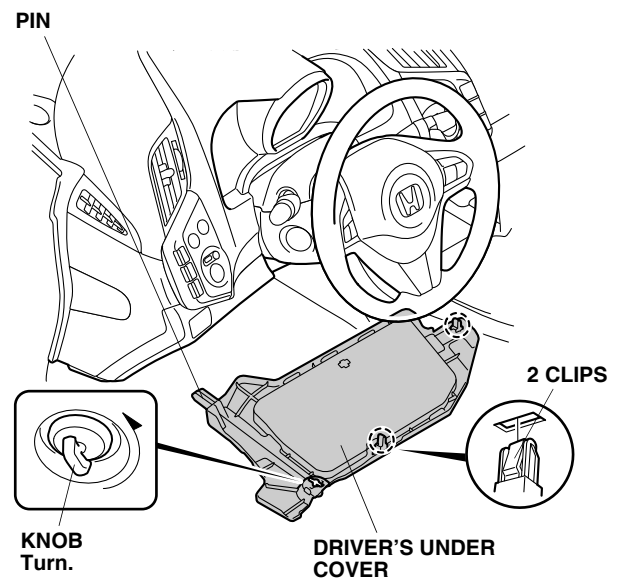

16. Pull away the door seal from the driver's kick panel. Remove the driver's kick panel (two clips and three retaining tabs). If the vehicle is equipped with footwell lights, unplug the vehicle connector.

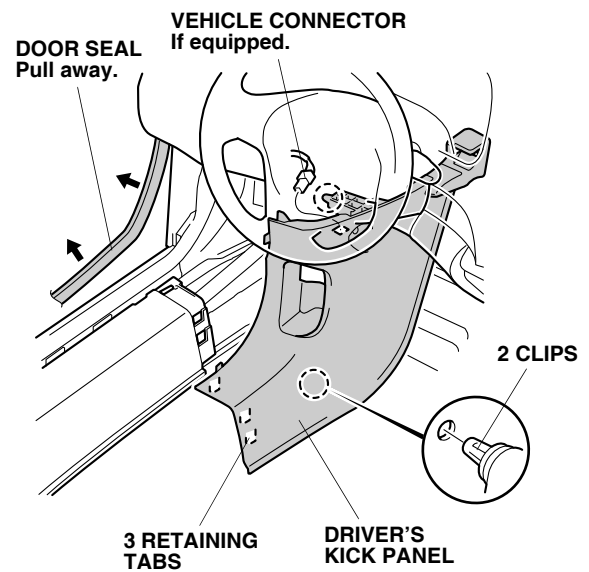

- Using needle nose pliers, remove the spring from the mirror holder. Install the new spring into the mirror holder.

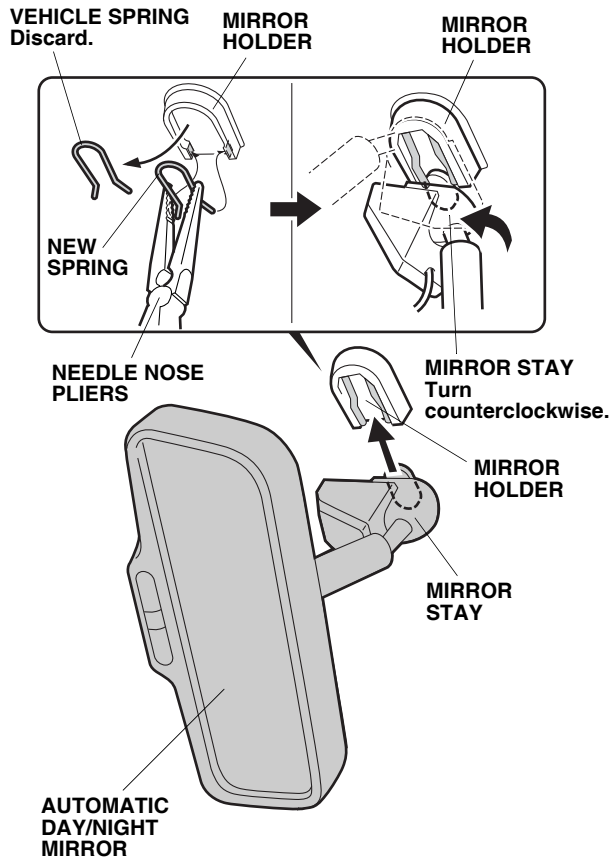

- Slide the automatic day/night mirror stay into the mirror holder. Then turn the mirror stay counterclockwise to secure the automatic day/night mirror in the holder.

- Using isopropyl alcohol on a shop towel, thoroughly clean the fuse case where the fuse label will attach. Attach the 2A fuse label to the fuse case on the automatic day/night mirror harness.

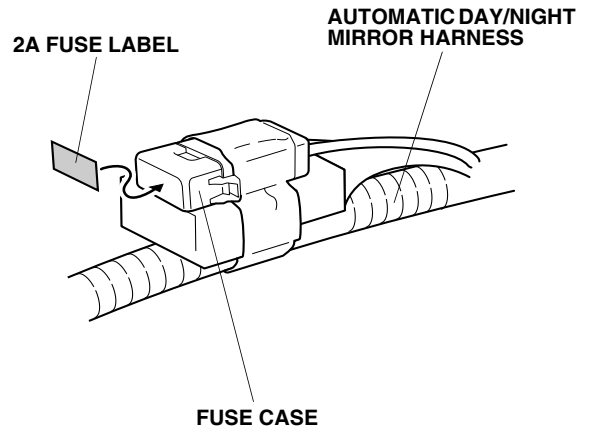

*Without Another Accessory Harness*

- At the fuse box, unplug the vehicle 8-pin connector. Plug the automatic day/night mirror harness 8-pin connector into the fuse box 8-pin connector. Plug the vehicle 8-pin connector into the automatic day/night mirror harness 8-pin connector as shown.

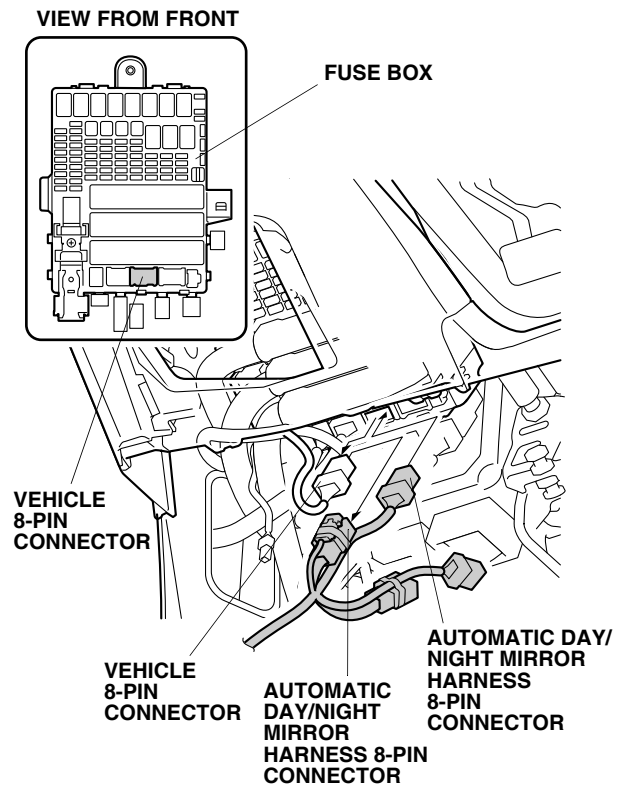

*With Another Accessory Harness*

21. Unplug the other accessory harness 8-pin connector from the fuse box. Plug the automatic day/night mirror harness 8-pin connector into the fuse box 8-pin connector. Plug the other accessory harness 8-pin connector into the automatic day/night mirror harness 8-pin connector
22. Unplug the vehicle 12-pin connector from the fuse box, and plug the automatic day/night mirror harness 12-pin connector into the fuse box 12-pin connector. Plug the vehicle 12-pin connector into the automatic day/night mirror harness 12-pin connector as shown.

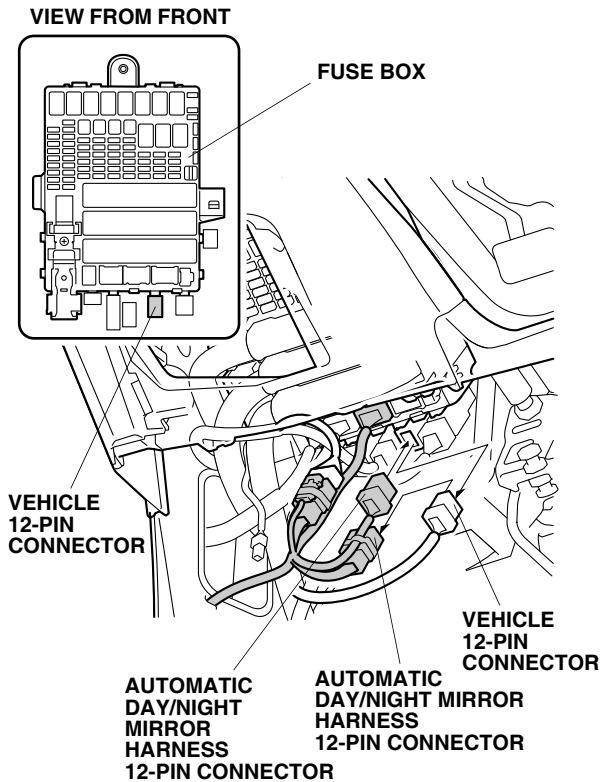

23. Secure the automatic day/night mirror harness to the vehicle harness with one wire tie.

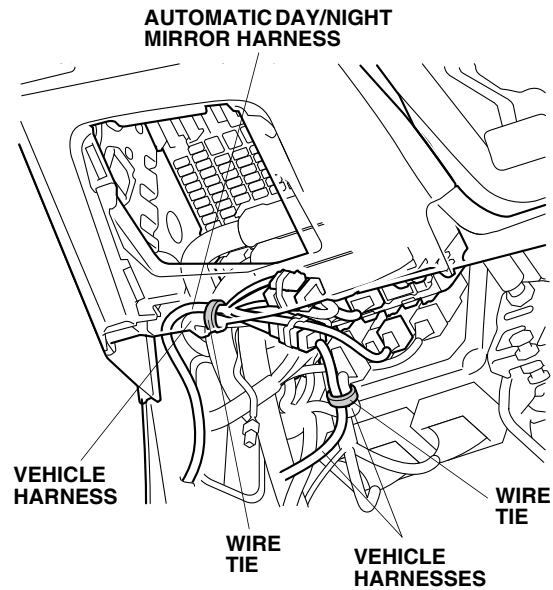

24. Secure the vehicle harness to the vehicle harness with one wire tie.
25. Pull away the door seal from the dashboard.

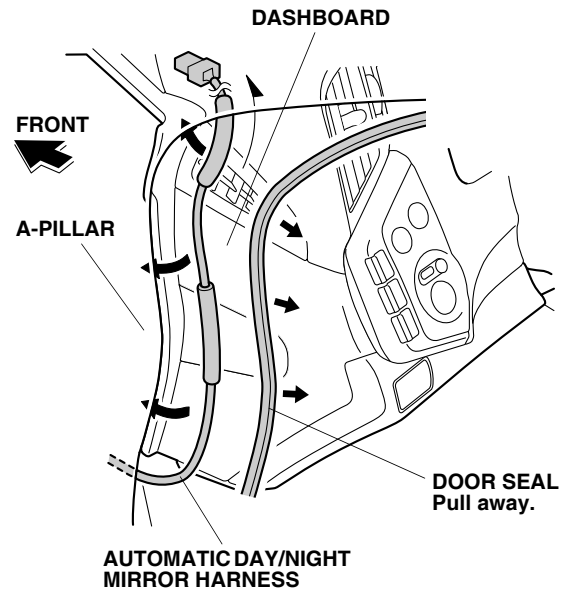

26. Route the automatic day/night mirror harness between the dashboard and the A-pillar.

- Align the green tape on the automatic day/night mirror harness with the vehicle clip, then secure the automatic day/night mirror harness to the vehicle harness with three wire ties.

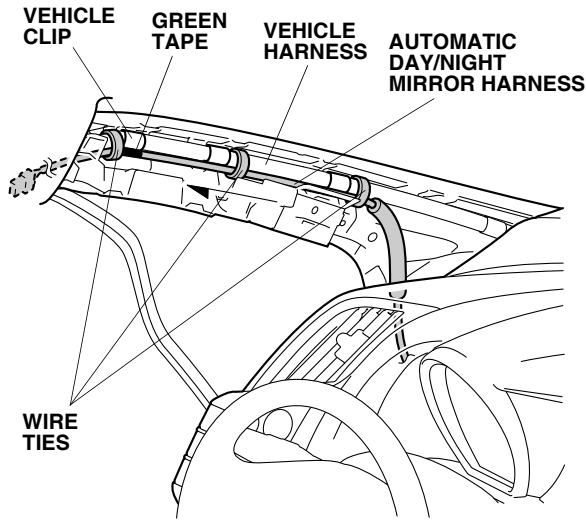

- Route the automatic day/night mirror harness behind the headliner as shown. Be careful not to crease the headliner.

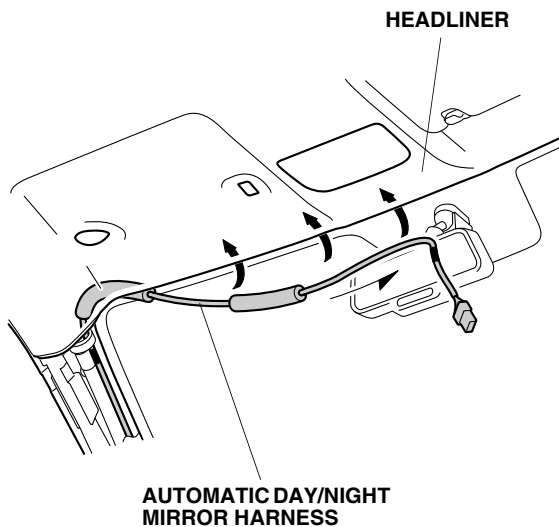

- Plug the automatic day/night mirror harness 7-pin connector into the automatic day/night mirror.

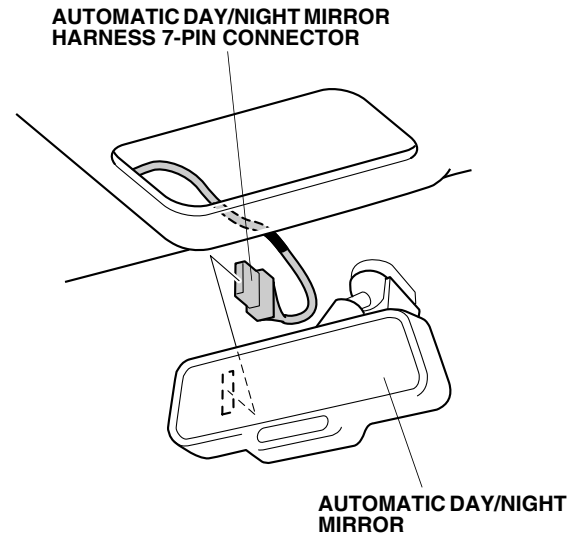

- Align the green tape on the automatic day/night mirror harness with the edge of the headliner. Route the automatic day/night mirror harness through the grooves in the harness cover. Secure the harness cover to the mirror stay.

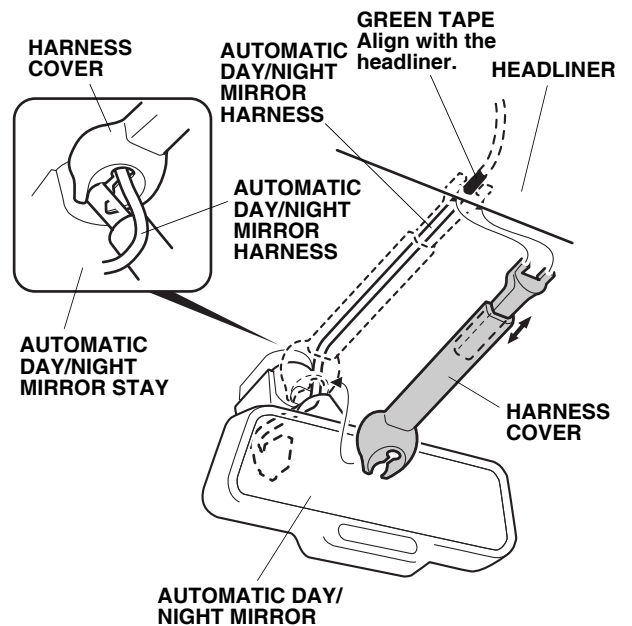

- Slide the upper end of the harness cover behind the headliner.

32. Using isopropyl alcohol on a shop towel, thoroughly clean the area where the EPT sealer will attach. Secure the automatic day/night mirror harness to the vehicle panel with one EPT sealer as shown.

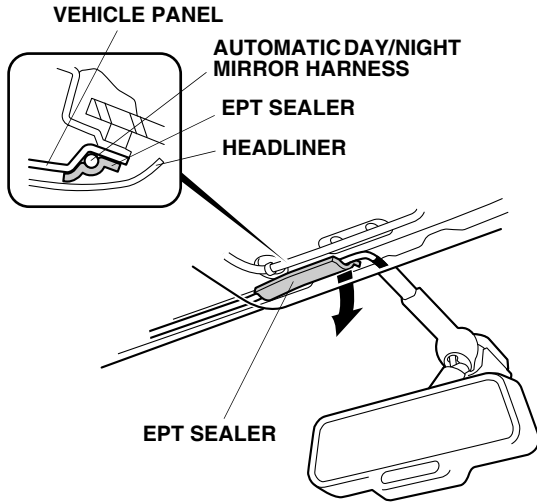

33. Remove and discard the vehicle clip from the driver's A-pillar trim. Install the new clip.

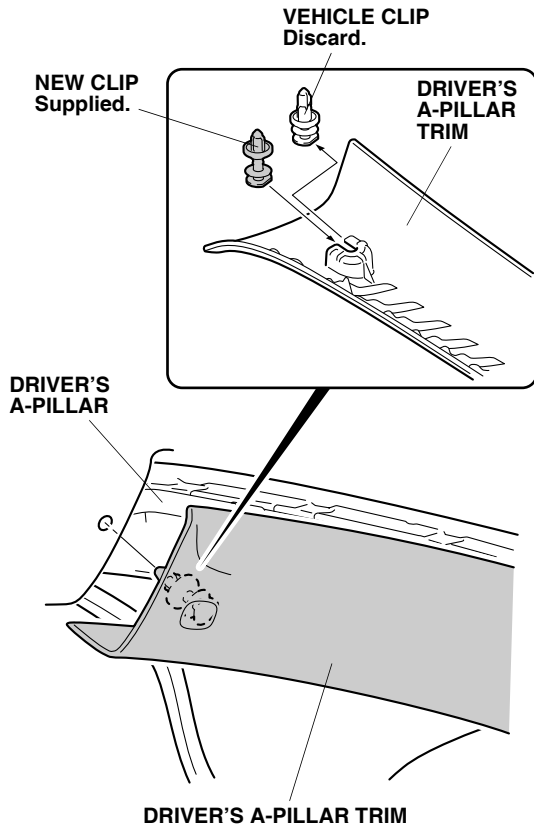

34. Reinstall the driver's A-pillar trim.  
 35. Check that all wire harnesses are routed properly and all connectors are plugged in.  
 36. Reinstall all removed parts.  
 37. Reconnect the negative cable to the battery.  
 38. Enter the customer's audio and navigation system (if equipped) anti-theft codes, and reset the radio station presets.  
 39. Reset the clock.  
 40. If the IMA battery level gauge display is at zero, start the engine and hold it between 3,500 rpm and 4,000 rpm (without load) in P or N position until the IMA battery level gauge display shows at least half-charged.  
 41. Do the Function Check to test the operation of the automatic day/night mirror.  
 42. Adjust the zone and calibrate as required.  
 43. Put the Operating Instructions in the glove box.

**Function Check**

1. Turn the ignition switch to ON (II), but do not start the engine.
2. Turn on the switch. Check that the LED illuminates.

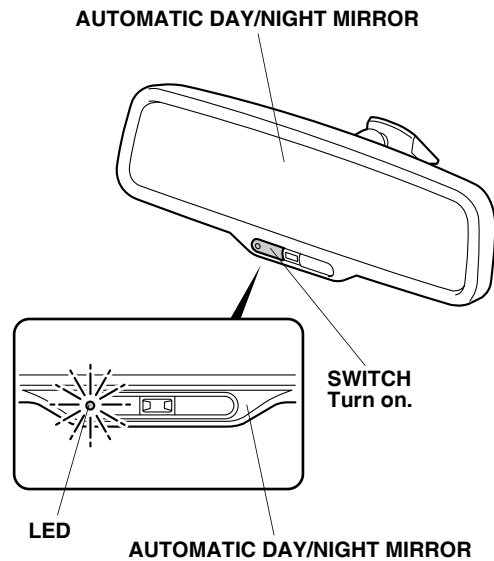



3. Cover the front sensor on the automatic day/night mirror with your hand, and use a flashlight to light the rear sensor on the mirror. Make sure the mirror surface dims.

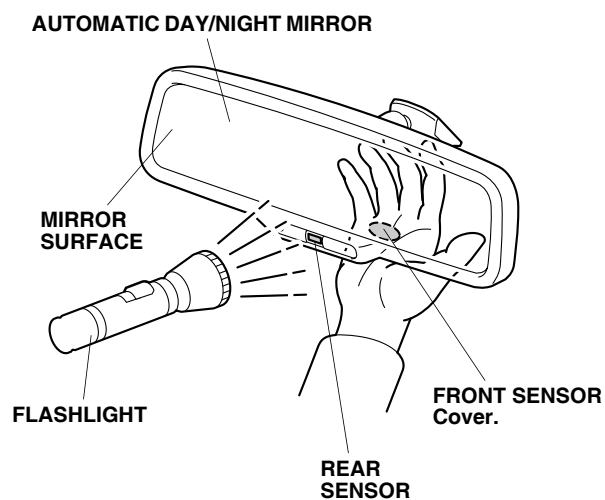

4. Make sure the parking brake is set. Step on the brake pedal, and move the shift lever to the “R” position. Repeat step 3, and make sure the mirror surface does not dim.
5. If the automatic day/night mirror does not function properly, check the fuse and all connectors, including the ground cable.