

**PARTS LIST**

Wing spoiler



Right trunk spring (marked red)



Left trunk spring (marked yellow)



Template

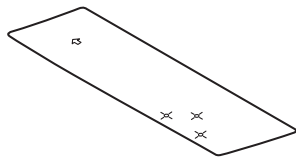

Urethane tape

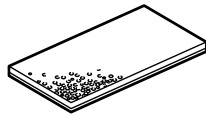

4 Cap nuts



Subharness



7 Wire ties

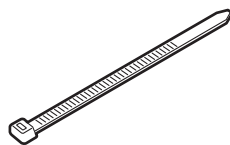

2 EPT sealers

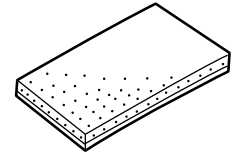
**TOOLS AND SUPPLIES REQUIRED**

Flat-tip screwdriver

Drill

3 mm, 6 mm, 8 mm, and 10 mm Drill bits

Eye protection (face shield, safety goggles, etc.)

Center punch

File

Touch-up paint

Felt-tip pen

Diagonal cutters

Isopropyl alcohol

Shop towel

Ratchet

10 mm Socket

Torque wrench

Ruler

Masking tape

Heavy gloves

High-quality paste wax

Trunk Spring Tool (T/N 07AAZ-S0KA100)

10 mm Open end wrench

## Illustration of the Wing Spoiler installed on the vehicle

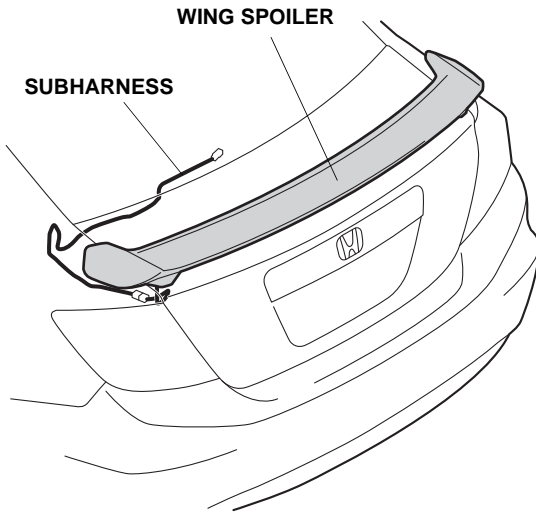

## INSTALLATION

**Customer Information:** The information in this installation instruction is intended for use only by skilled technicians who have the proper tools, equipment, and training to correctly and safely add equipment to your vehicle. These procedures should not be attempted by "do-it-yourselfers."

### NOTE:

- Be careful not to damage the paint finish.
- This wing spoiler kit should be installed only if the ambient air temperature is 15°C (60°F) or above.
- Clean and wax the areas to be covered with a high-quality paste wax.
- To allow the adhesive to cure, do not wash the vehicle for 24 hours. Please advise the customer.

1. Disconnect the negative cable from the battery.
2. Open the trunk lid. If equipped, remove the trunk lid trim panel (11 clips).

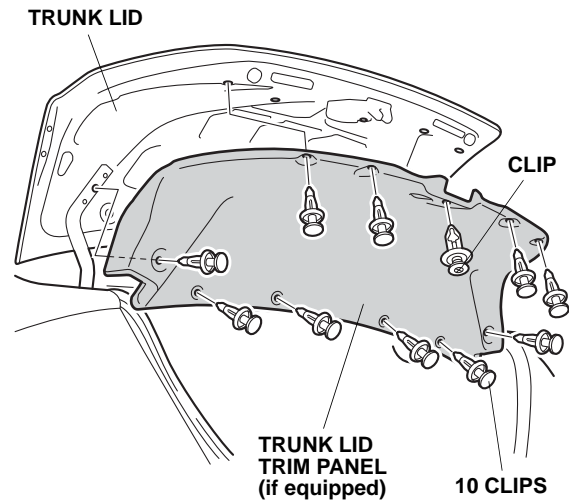

### Installing the Wing Spoiler

3. Close the trunk lid. Attach masking tape to the trunk lid as shown.

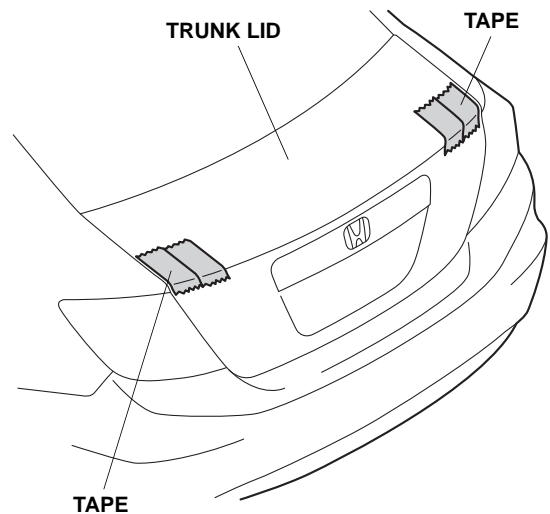

- Align the edge of the template to the edge of the trunk lid as shown, and attach it with masking tape.

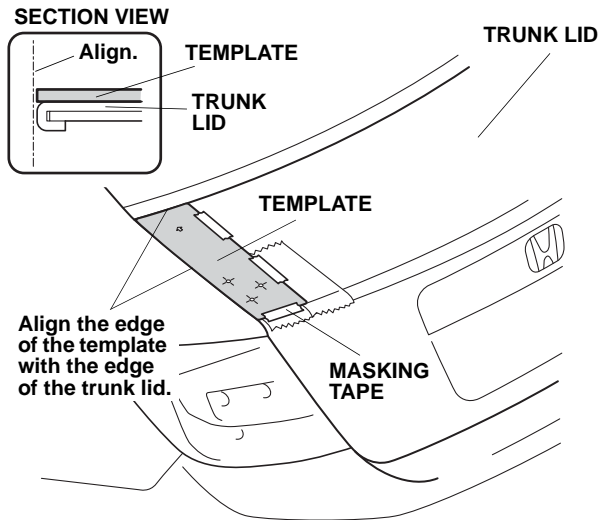

- Using a felt-tip pen, mark three holes on the masking tape through the template.

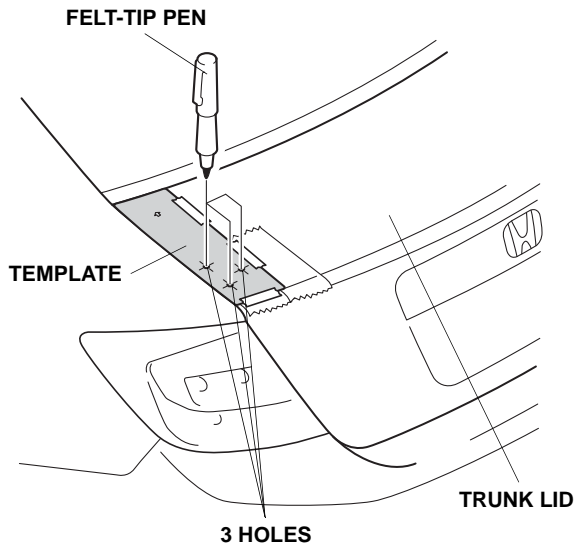

- Remove the template.

- Turn the template over. Align the edge of the template to the edge of the trunk lid as shown, and attach it with masking tape.

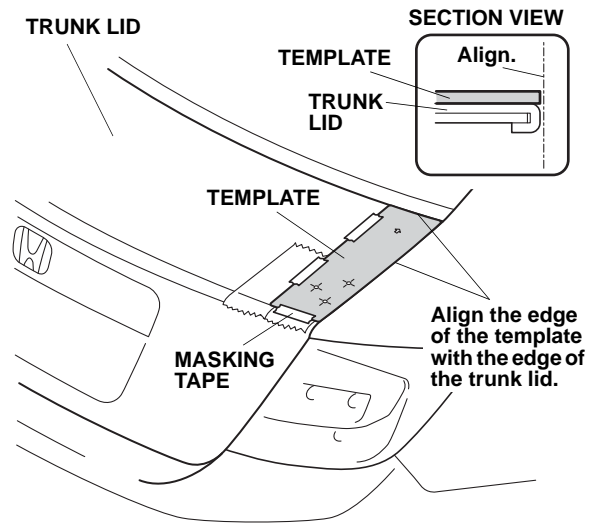

- Using a felt-tip pen, mark two holes on the masking tape through the template as shown.

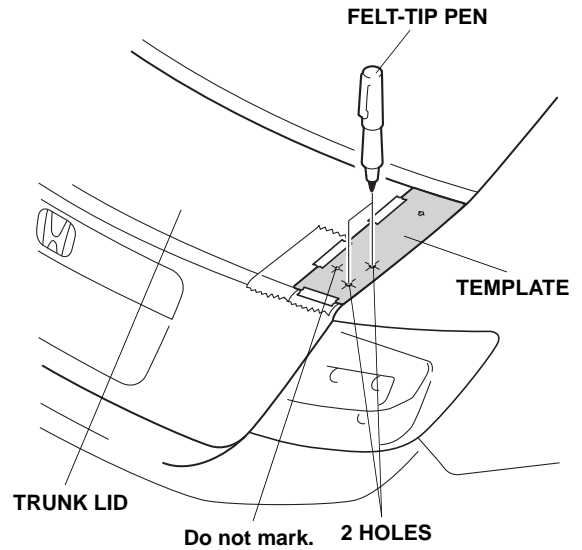

- Remove the template.

10. Using a center punch, mark the centers of the five marks. Set the center punch to the minimum power setting.

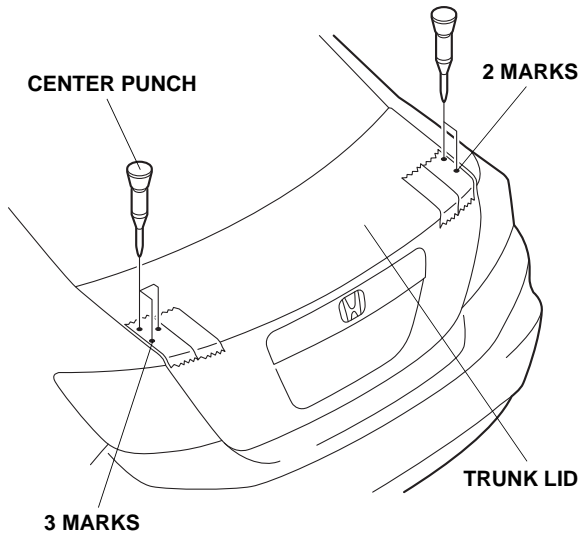

11. While wearing eye protection, drill four 8 mm holes through the marks. First drill with a 3 mm drill bit, then with a 6 mm drill bit, and finish with an 8 mm drill bit. Drill perpendicularly to the trunk lid.

- To prevent drilling through the inner panel, wrap tape around the drill bit 10 mm (0.4 in.) away from the tip.
- Take care not to damage the wire harnesses when drilling the holes.

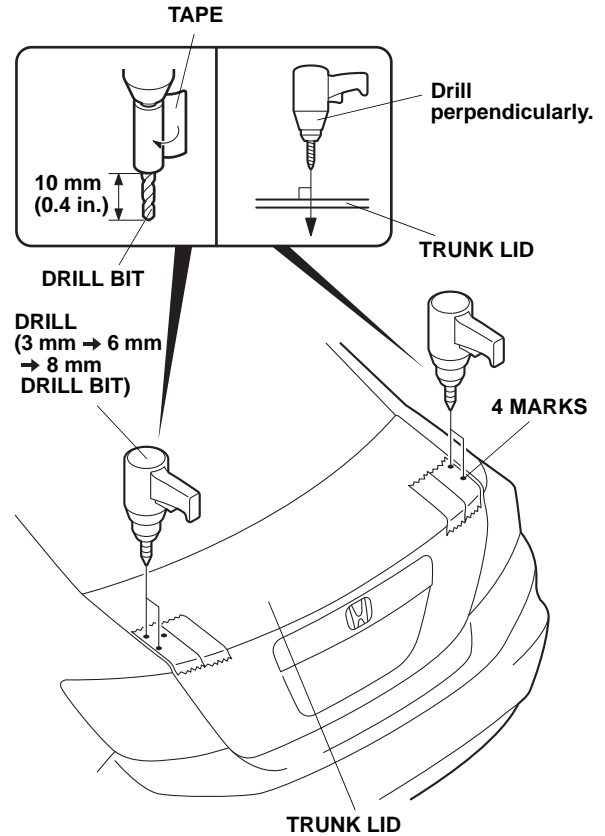

12. While wearing eye protection, drill a 10 mm hole through the remaining mark. First drill with a 3 mm drill bit, then with a 6 mm drill bit, and finish with a 10 mm drill bit. Make sure to drill perpendicularly to the trunk lid.

- To prevent drilling through the inner panel, wrap a strip of tape around the drill bits 10 mm (0.4 in.) away from the tip.
- Take care not to damage the wire harnesses when drilling the holes.

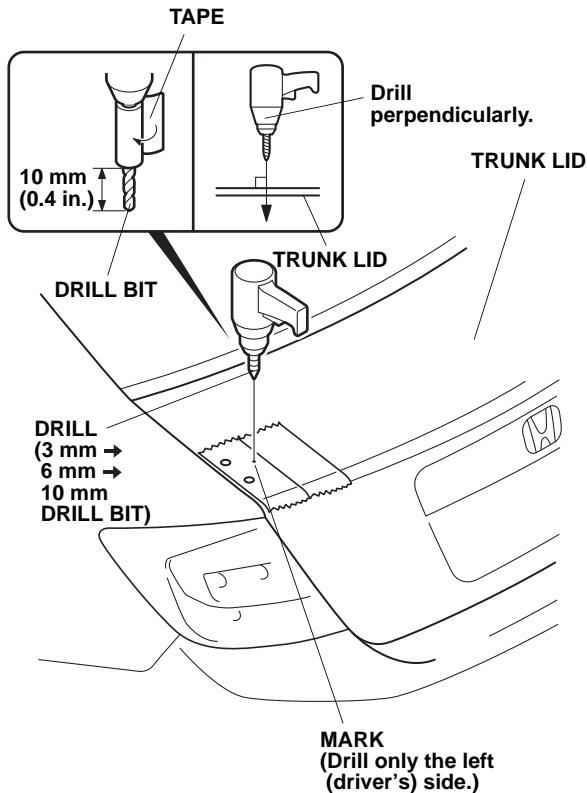

13. Remove the masking tape attached in step 3. Remove all burrs and metal shavings with a file, and apply touch-up paint to the edges of the holes you drilled.

14. Fit the four studs on the wing spoiler into the four 8 mm holes to check the hole positions. If the holes/studs do not align, enlarge the holes with a file and apply touch-up paint. After the paint has dried, check the alignment again.

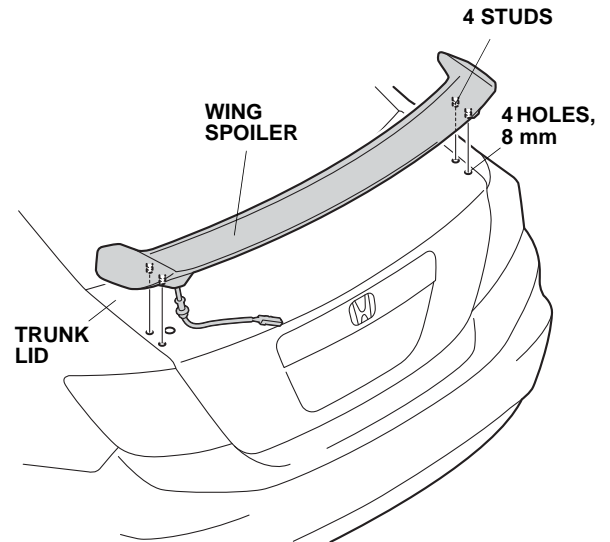

15. Remove the wing spoiler.

16. Using isopropyl alcohol on a shop towel, thoroughly clean the areas where the wing spoiler will attach.

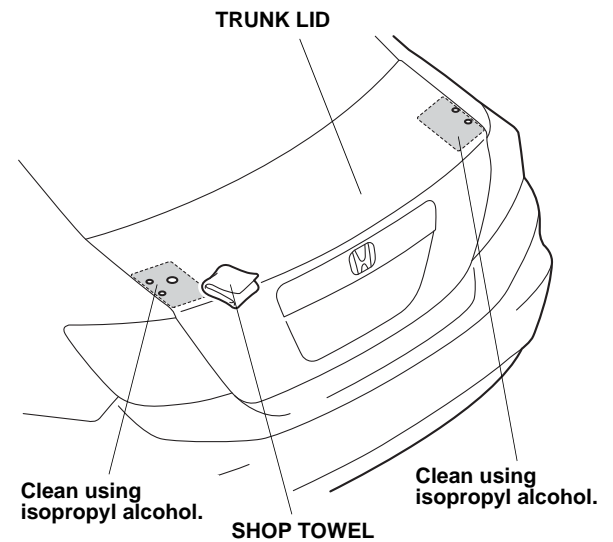

17. Route the wing spoiler harness down through the 10 mm hole. Attach the grommet to the 10 mm hole. Route the wing spoiler harness 2-pin connector as shown.

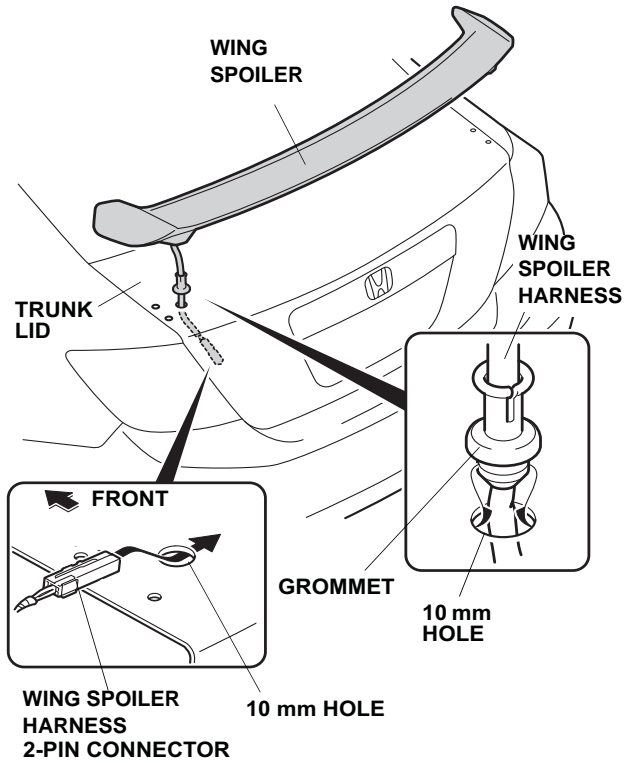

18. Insert the four studs into the 8 mm holes in the trunk lid.

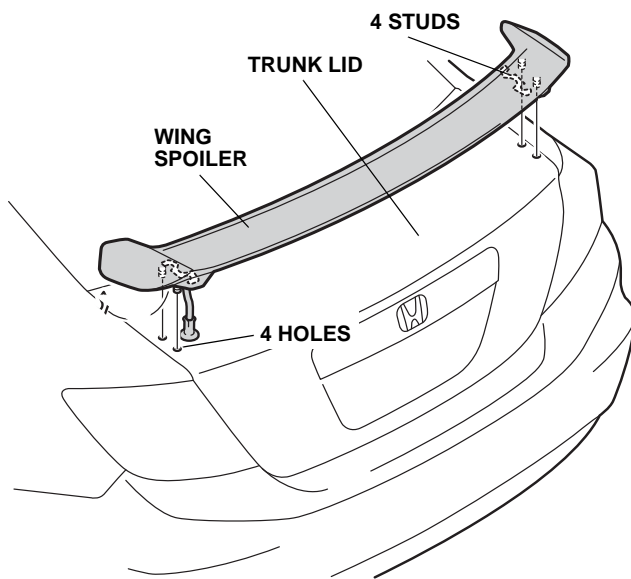

19. Open the trunk lid. Install four cap nuts on the four wing spoiler studs. Torque the cap nuts to 8.8 N·m (0.9 kgf·m, 6.5 lbf·ft).

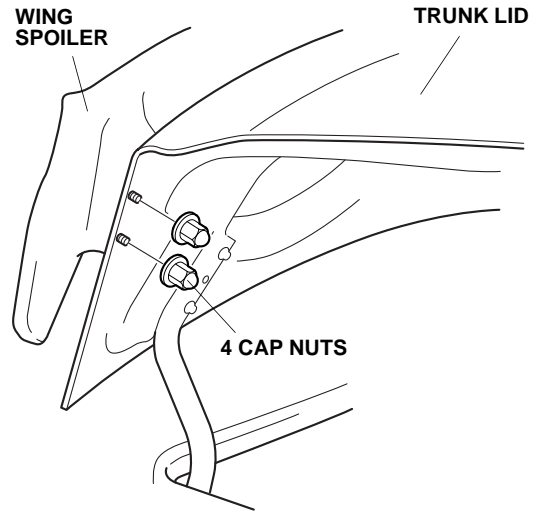

### Installing the Trunk Springs

20. Push the tabs, and pull down the two seat-back release levers to release the hooks. Move two seat-back release levers out of your way.

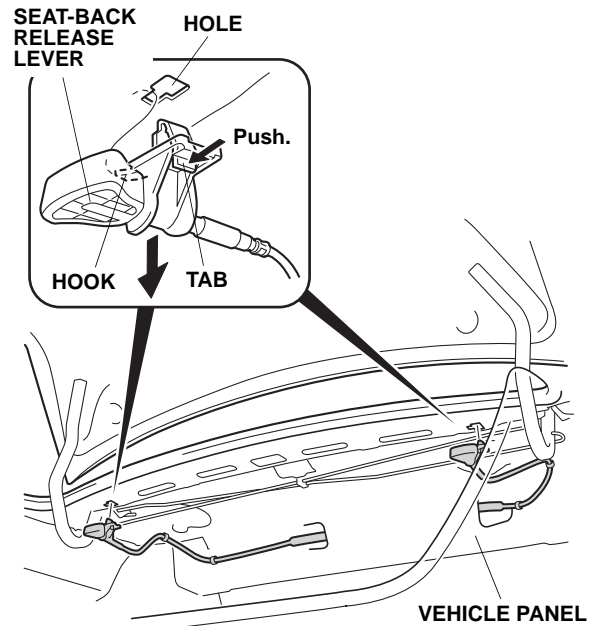

21. Remove the center clip from the left and right trunk springs.

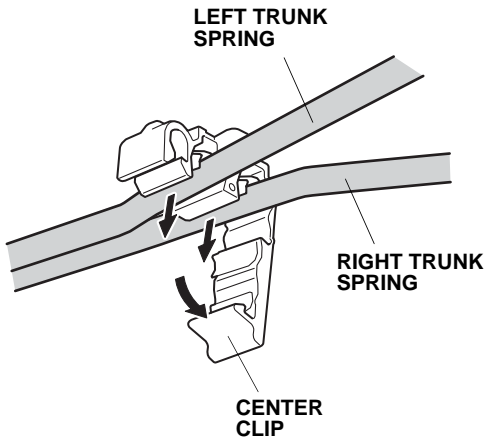

22. Put on heavy gloves to protect your hands. With an assistant holding the trunk lid open, remove both trunk springs with the trunk spring tool. Pull the trunk spring tool slowly and carefully toward you. First remove the left trunk spring, then remove the right trunk spring.

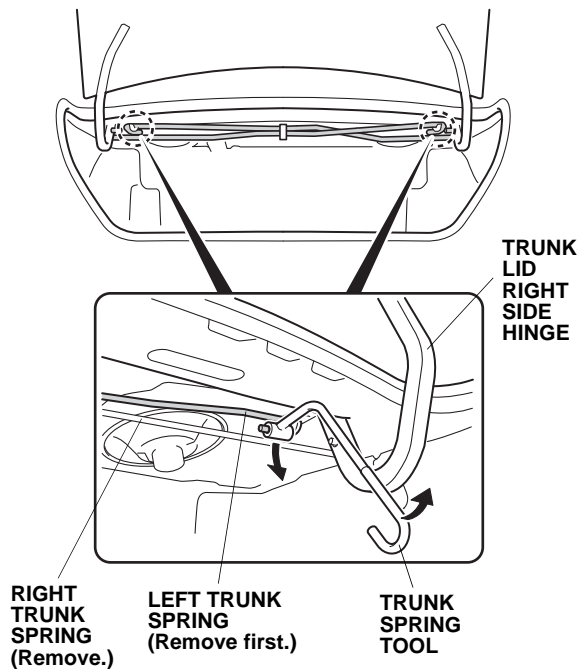

23. Install the red marked trunk spring in the slot in the trunk lid right (passenger's) hinge and to the left (driver's) hinge bracket. install the yellow marked trunk spring in the slot in the trunk lid left (driver's) hinge and to the right (passenger's) hinge bracket. NOTE: If the vehicle is not equipped with a trunk lid trim panel, set the trunk springs in the first notch of the hinge brackets. Set the trunk springs in the second notch of the hinge brackets if the vehicle is equipped with a trunk lid trim panel.

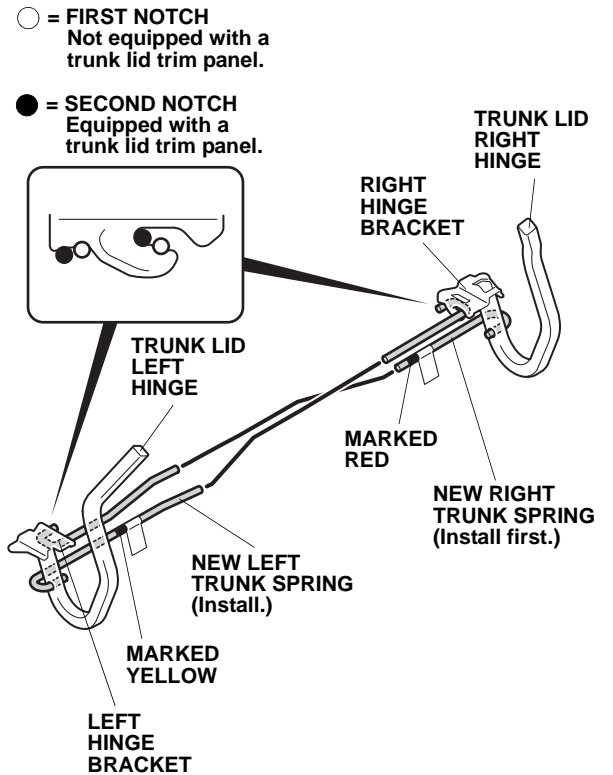

24. Install the center clip onto the new right and left trunk springs.

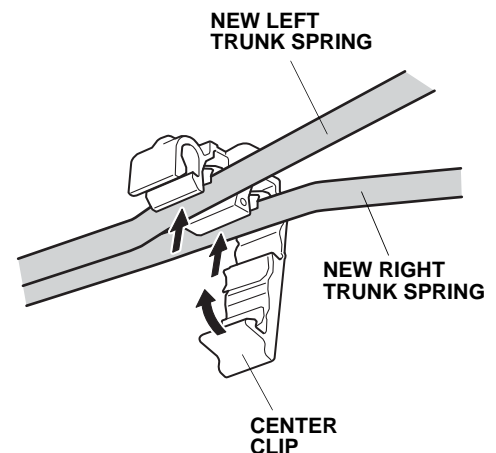

## Routing the Subharness

25. Remove two clips from the trunk left side lining.

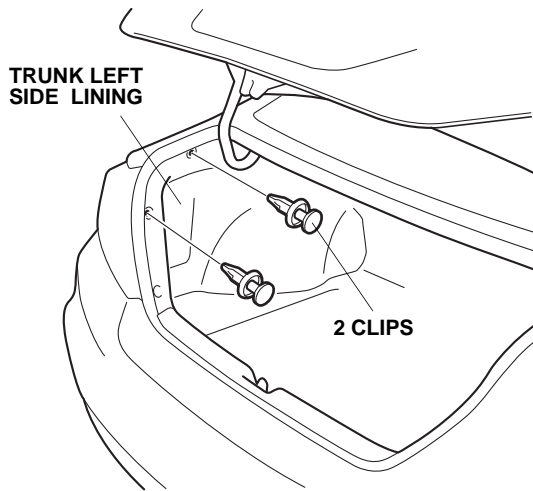

26. Using isopropyl alcohol on a shop towel, thoroughly clean the area where the urethane tape will attach.

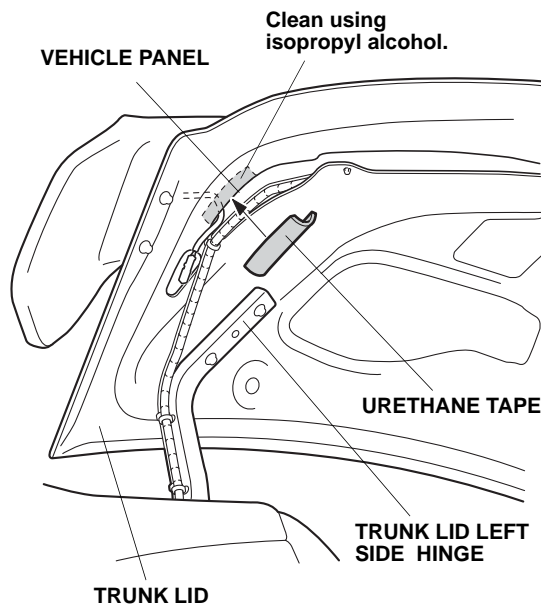

27. Apply the urethane tape to the vehicle panel as shown.

28. Secure the trunk spoiler harness to the vehicle harness with one wire tie. Do not secure the wire tie to the trunk opener cable.

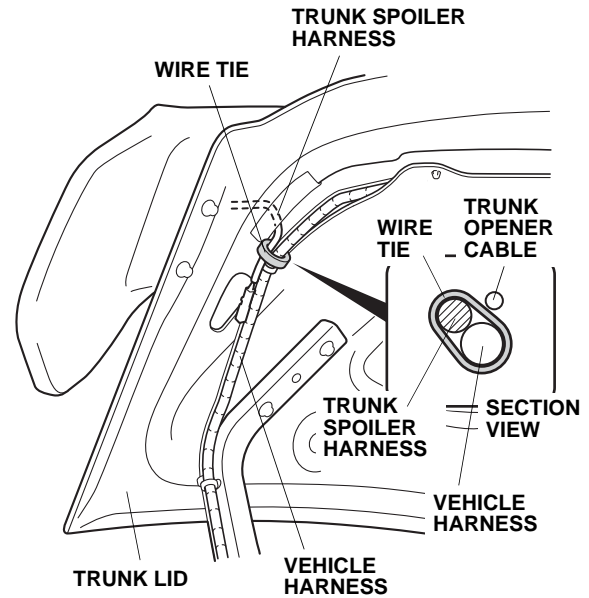

29. Route the subharness through the holes in the vehicle panel as shown.

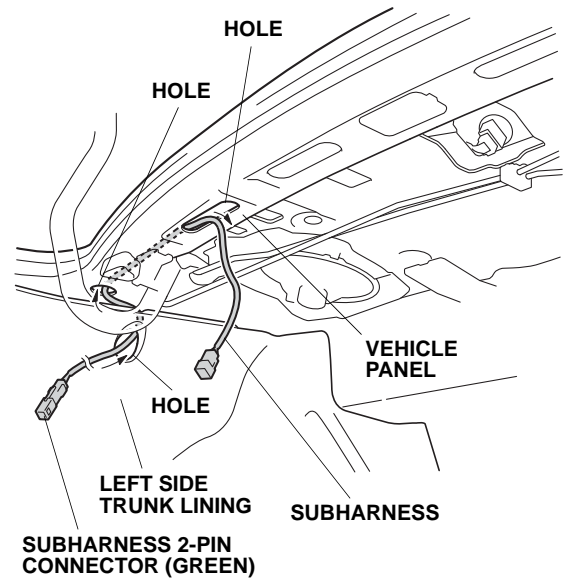



30. Route the subharness through the holes in the vehicle panel as shown.

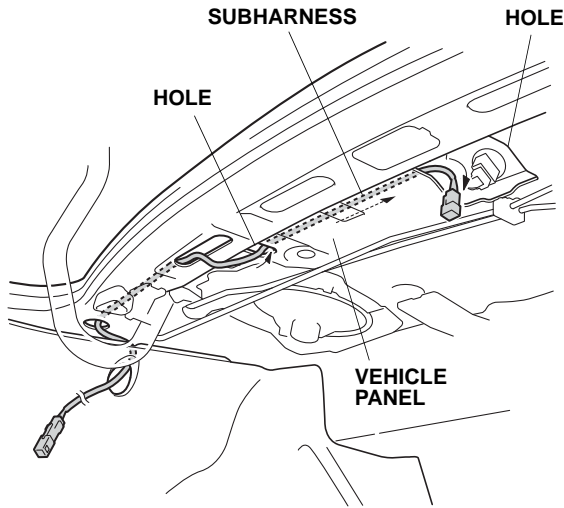

31. Unplug the vehicle 2-pin connector from the high-mount brake light connector.

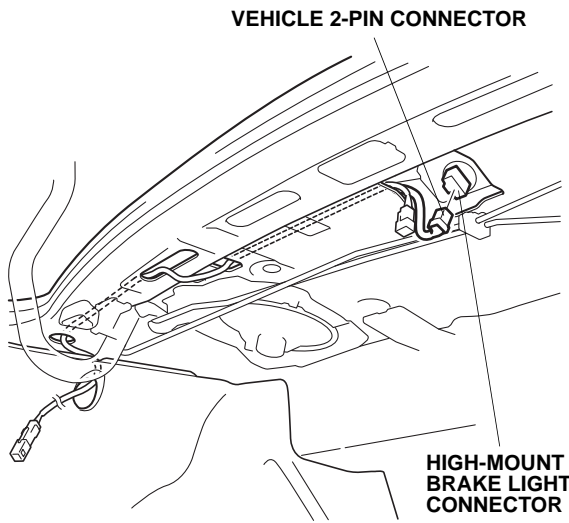

32. Plug the vehicle 2-pin connector into the subharness 2-pin connector. Wrap one EPT sealer around the vehicle 2-pin connector and the subharness 2-pin connector.

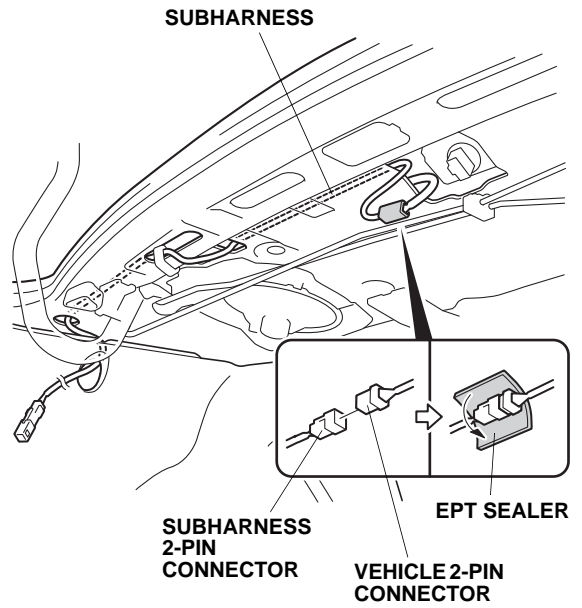

33. Align the green tape on the subharness with the vehicle clip, and secure the subharness to the vehicle harness with one wire tie.

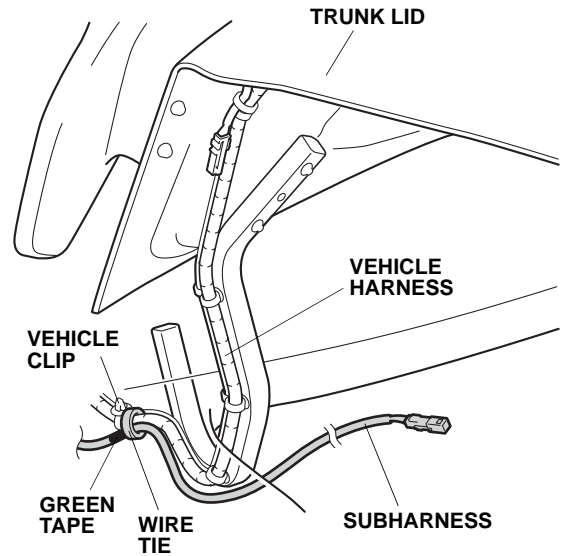

34. Join a wire tie with another wire tie as shown, and secure the subharness to the vehicle panel with the joined wire ties.

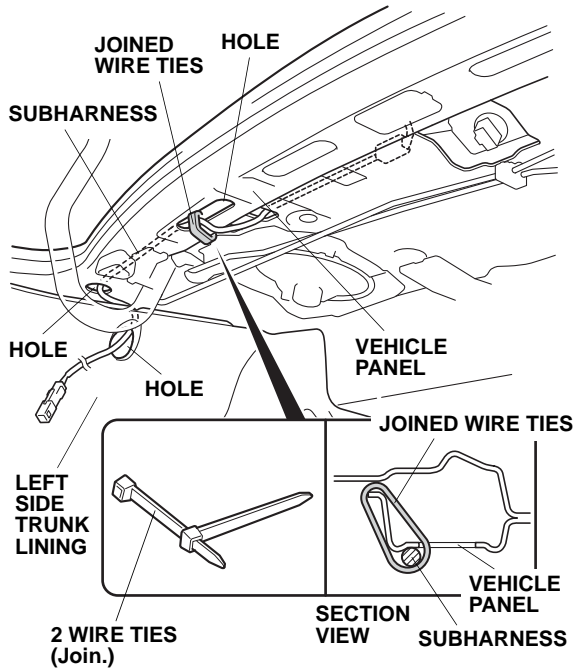

35. Plug the trunk spoiler harness 2-pin connector into the subharness 2-pin connector. Wrap one EPT sealer around the trunk spoiler harness 2-pin connector and the subharness 2-pin connector.

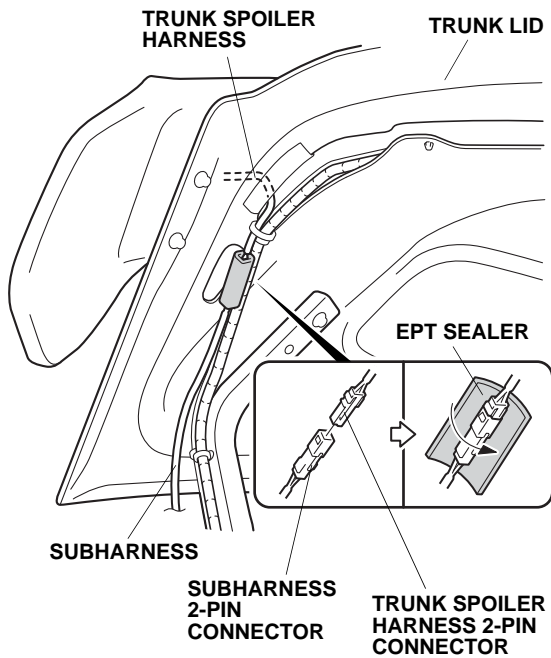

36. Secure the subharness to the vehicle harness with three wire ties in the area shown. Do not secure the wire tie to the trunk opener cable.

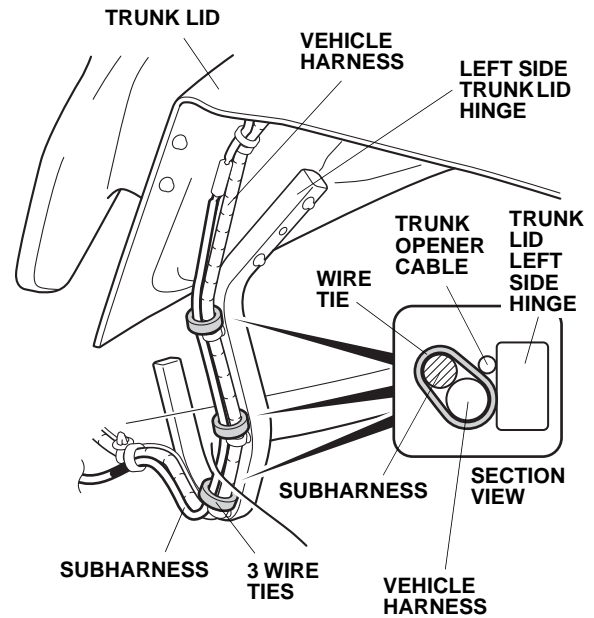

37. Check that all wire harnesses are routed properly and all connectors are plugged in.
38. Reinstall all removed parts.
39. Reconnect the negative cable to the battery, and check the operation of all of the lights.
40. Press and hold the radio power button for two seconds to restore radio and navi (if equipped) system functions.
41. Reset the clock on vehicles without navigation.