



INSTALLATION INSTRUCTIONS

Accessory
18" ALUMINUM WHEEL
 P/N 08W18-TA0-100
 P/N 08W18-TA0-100A

Application
2011 ACCORD
2- AND 4-DOOR

Publications No.
All 43990

Issue Date
AUG 2010

PARTS LIST

Aluminum wheel
 (The illustration may differ from the actual wheel.)

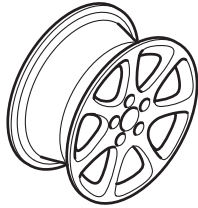

Wheel center cap
 (The illustration may differ from the actual center cap.)

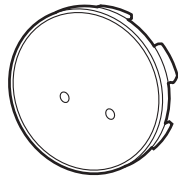

Center cap emblem

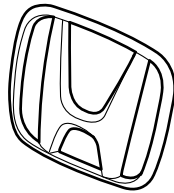

2 Push nuts



Tire pressure information label



TPMS Information
 (Give this information to your customer.)

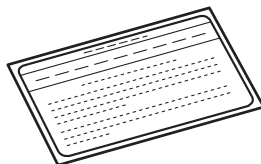

Wheel cleaning information
 (Included with 08W18-TA0-100A only.
 Give this information to your customer.)

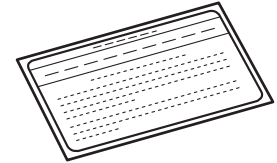

Supplemental information

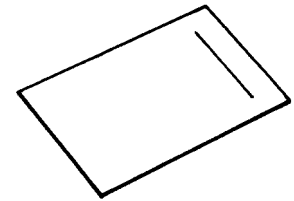

Parts for TPMS sensor assembly

Tire pressure sensor assembly

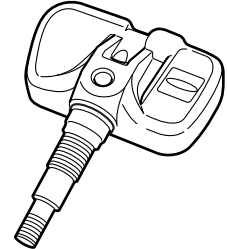

Washer



Valve cap

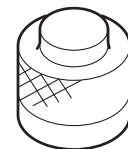

Valve nut



TOOLS AND SUPPLIES REQUIRED

Ratchet wrench
11 mm Socket
Torque wrench
Isopropyl alcohol
Shop towel
HDS
TPMS sensor initializer tool T/N AKS0620006

SPECIFICATIONS

Models not equipped with standard 18" wheels:

Rim size	18 x 7 1/2 J (offset 55)	
Tire size	225/45R18 95Y	
Bolt hole PCD	114.3 (5 holes)	
Tire pressure	Front	270 kpa (2.8 kgf/cm ² , 39 psi)
	Rear	270 kpa (2.8 kgf/cm ² , 39 psi)

Models equipped with standard 18" wheels:

Refer to the Owner's Manual.

INSTALLATION

Customer Information: The information in this installation instruction is intended for use only by skilled technicians who have the proper tools, equipment, and training to correctly and safely add equipment to your vehicle. These procedures should not be attempted by "do-it-yourselfers."

NOTE:

- This aluminum wheel is designed for use on TPMS (Tire Pressure Monitoring System)-equipped vehicles.
- This aluminum wheel is equipped with a TPMS sensor. See the Service Manual for tire replacement procedure and TPMS sensor installation procedure.
- Install the correct size tire.
- The wheel nut torque is 108 N·m (80 lbf·ft).
- Use a tire changer to install and remove the tires. Do not use a tire lever, as it may cause damage to the tire and aluminum wheel.
- Be careful not to damage the wheel center cap when installing the emblems.
- The center cap emblem kit should be installed only if the ambient air temperature is 60°F (15°C) or above.
- To allow the adhesive to cure, do not wash the vehicle for 24 hours.

- Using isopropyl alcohol on a shop towel, clean the area where the center cap emblem will attach.

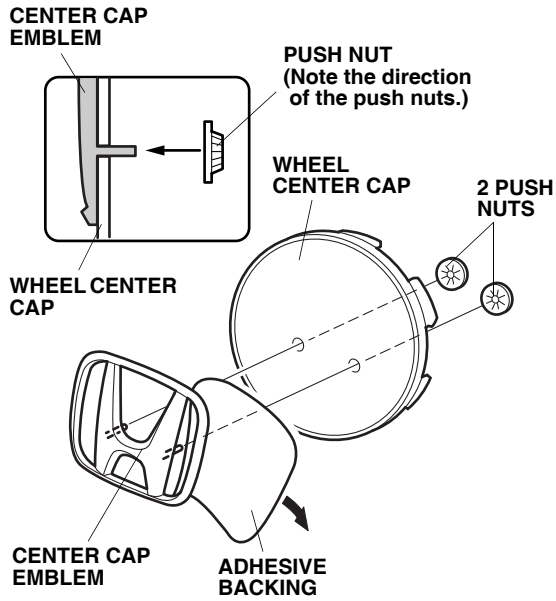

- Remove the adhesive backing from the center cap emblem.
- Attach the center cap emblem to the wheel center cap by aligning its pins with the holes in the wheel center cap. After attaching, hold the emblem firmly against the wheel center cap with the palm of your hand for 30 seconds.
- Slide the push nuts onto the pins. Note the direction of the push nuts.

- Before installing the tire pressure sensor, clean the mating surface on the sensor and the aluminum wheel.
- Install the tire pressure sensor and the washer on the aluminum wheel, and tighten the valve nut finger tight. Make sure the pressure sensor is resting on the wheel.

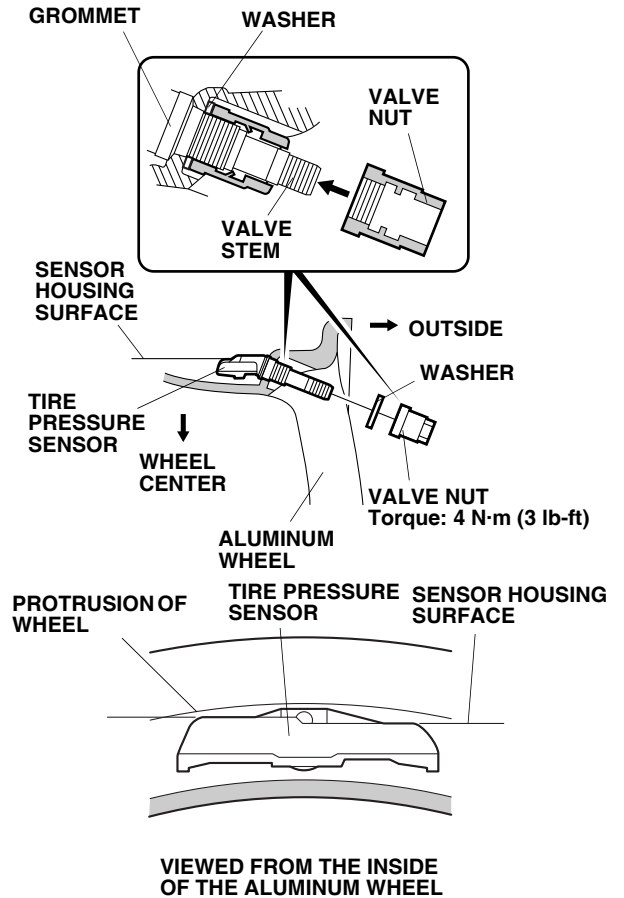

7. While holding the tire pressure sensor to keep it from rotating, torque the valve nut to 4 N·m (0.4 kgf·m, 3 lbf·ft). You may hear a snap or pop as you torque the nut; this is normal.

NOTE:

- Install the tire pressure sensor so the sensor housing surface does not protrude into the bead area of the wheel.
 - Do not reuse a grommet that has been tightened, even one time, to the specified torque. The valve stem may leak.
 - Do not use pneumatic or electric tools on the valve nut.
 - Tightening the nut above the specified torque can damage the grommet.
 - Make sure that there is no space between the sensor and the wheel.
8. Install the tires according to the instructions in the service manual.
 9. Install the wheels on the vehicle and torque the wheel nuts to 108 N·m (80 lb·ft).

MEMORIZING THE TIRE PRESSURE SENSOR ID

10. Using the HDS and the TPMS sensor initializer tool, memorize the tire pressure sensor ID according to the instructions in the service manual.

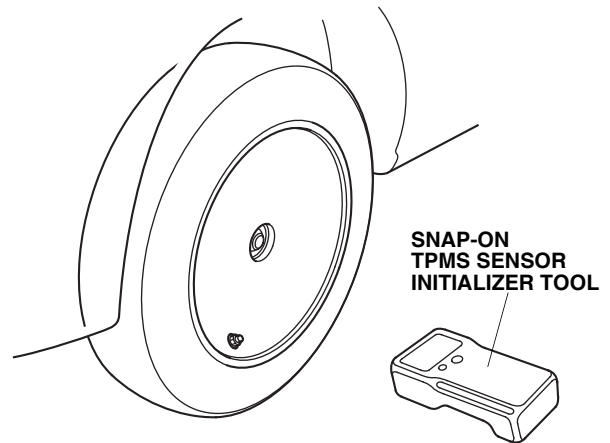
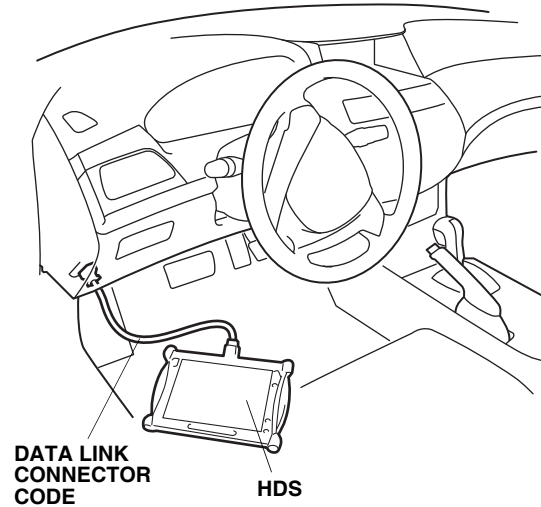

11. Open the driver's door. Using isopropyl alcohol, thoroughly clean the area of the driver's doorjamb where the Tire Pressure Information Label will attach. Remove the adhesive backing from the label, and apply it over the standard label.

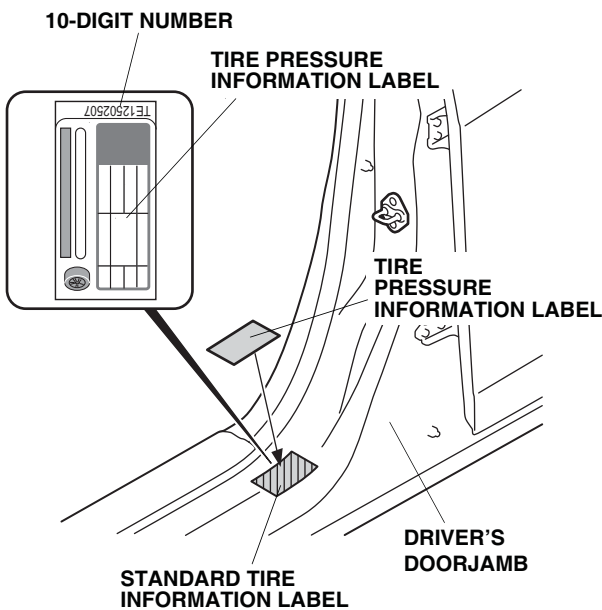

12. *Models equipped with standard 18" wheels:* Insert the Supplemental Information page included in this kit into the owner's manual.
13. Do the Inch-up Tire Pressure Programming procedure on page 6.
14. After finishing the work, write the tire size, tire pressure, HDS version, dealer name, technician's signature, and date in the "Service History Page for Honda Accessory Alloy wheels" page included in this kit, and attach the page to the vehicle's service history booklet.

- Be sure to explain the contents of the "Supplemental Information" to your customer before delivering the vehicle.
- Be sure to give the wheel cleaning information and TPMS information to your customer.

INCH-UP TIRE PRESSURE PROGRAMMING (LOW AIR PRESSURE WARNING THRESHOLD REPROGRAMMING)

1. After doing the sensor ID learning using the HDS, back up to the TPMS Mode Menu, and click on Threshold Rewriting.
2. Select "Reprogramming for accessory tires."
3. When the HDS says "Do you want to rewrite the threshold data?" click "YES."
4. Check that "Please enter the tire information code of new tires" is shown, and click the "Keyboard" icon.
5. Enter the 10-digit tire information code printed on the new tire pressure information label, then click the check icon.
6. Check that the tire pressure shown on the HDS is the same as the new tire pressure on the tire information label, then click the "YES" button for programming.
7. Check that the current air pressure setting shown on the HDS is correct and "Reprogramming the threshold data for non-standard tires has completed successfully" is shown.
8. After programming, write the tire pressure indicated on the HDS in the service history page for Honda Accessory Wheels, then click the check icon.

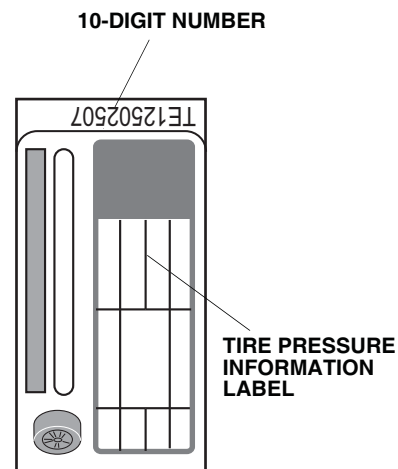
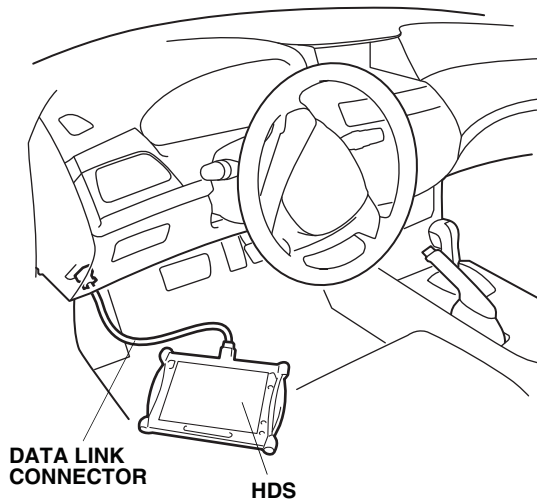

REINSTALLING STANDARD TIRES

To return the TPMS programming from the inch-up tire to the standard tire, change the programming using the following procedure.

1. Connect the HDS to the vehicle, make sure the correct VIN is populated, and enter the mileage.
2. At the System Selection Menu, click TPMS.
3. At the Mode Menu, Click the DTC and clear any stored codes.
4. Go back to the Mode Menu, click on Threshold Rewriting.
5. Click on Reprogramming for standard tires and follow the screen prompts.
6. After programming, write the measured tire pressure in the Service History book, then click the check button.
7. Attach the tire pressure information label for standard tire over the current label in the driver's doorjamb.
8. Sign on the service history page for Honda Accessory wheels (step 14 on page 5).

STANDARD TIRE PRESSURE PROGRAMMING

If the original equipment (standard tires) are reinstalled on the vehicle, the low pressure warning threshold must be restored to the factory setting.

NOTE: Have the standard tire pressure label on hand.

THRESHOLD DATA CHECK

If you are unsure of where the low pressure warning threshold is set, it can be checked by using the Threshold Data Check.

Check the TPMS programming on the vehicle:

1. Connect the HDS to the vehicle and make sure the correct VIN is populated, then enter the mileage.
2. At the System Selection Menu, click TPMS.
3. Click on Threshold Rewriting.
4. Click on Threshold Data Check.

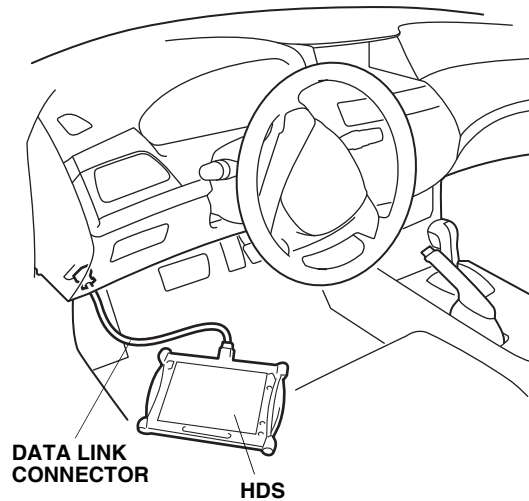

TPMS Control Unit Replacement

If the TPMS unit is replaced, do steps 10-14 (Memorizing the Tire Pressure Sensor ID and Inch-Up Tire Pressure Programming).