

PARTS LIST

**XM Radio Attachment (sold separately):
P/N 08B15-SNA-100B**

Bus cable

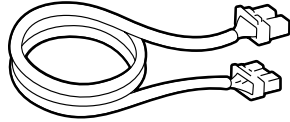

Front bracket

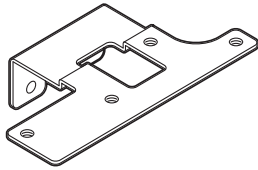

Rear bracket

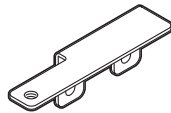

Clip



4 Pan screws

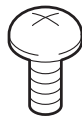

4 Washers



3 Flange bolts

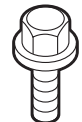

Cover seal

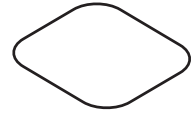

20 Wire ties
(1 Not used)

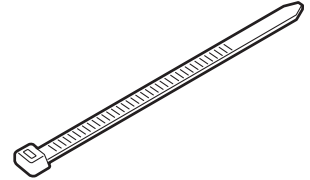

7 Wire ties with clip
(2 Not used)

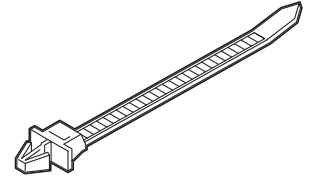

12 Cushion tapes
(4 Not used)



8 EPT sealers
(Some may not be used.)

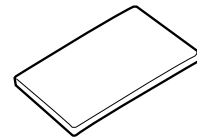

**XM Antenna (sold separately):
P/N 08A15-0J1-100**

Antenna assembly

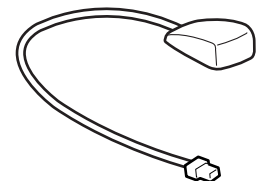

**XM Radio Unit (sold separately):
P/N 08A15-3J1-000**

XM radio unit

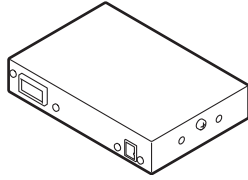

**2-Port Bus Cable (sold separately):
P/N 08A31-0F1-000**

2-Port bus cable

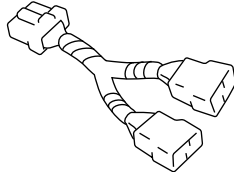

TOOLS AND SUPPLIES REQUIRED

- Phillips screwdriver
- Flat-tip screwdriver
- Ruler
- Shop towel
- Scissors
- Ratchet
- 10 mm Socket
- 10 mm Combination wrench
- Isopropyl alcohol
(Isopropyl alcohol, in a 60/40 solution with water)
- Rubber mallet
- TORX bit
- Diagonal cutters
- Masking tape
- Plastic Trim Tool (T/N SILTRIMTL10)

Illustration of the XM Radio System Installed on the Vehicle

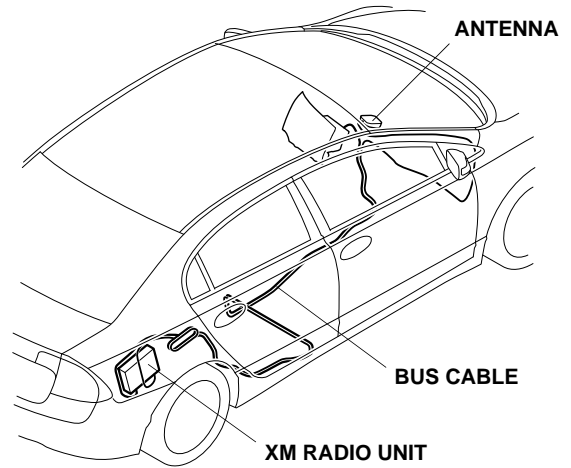

6623010H

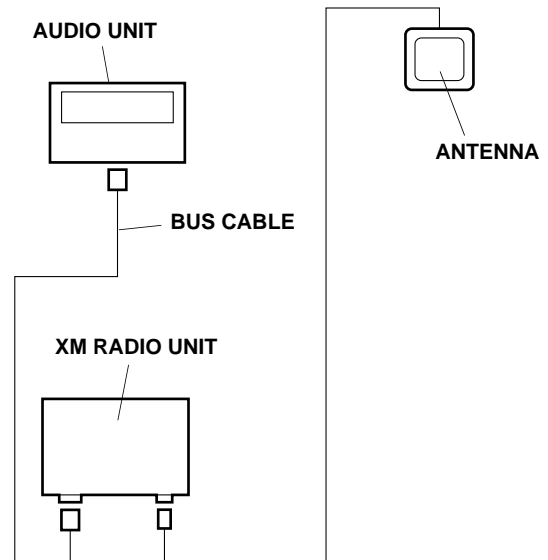

INSTALLATION

Customer Information: The information in this installation instruction is intended for use only by skilled technicians who have the proper tools, equipment, and training to correctly and safely add equipment to your vehicle. These procedures should not be attempted by “do-it-yourselfers.”

1. Make sure you have the anti-theft codes for the audio and navigation system (if equipped), then write down the audio presets.
2. Disconnect the negative cable from the battery.
3. Remove the passenger's dashboard lower cover (four clips and two pins).

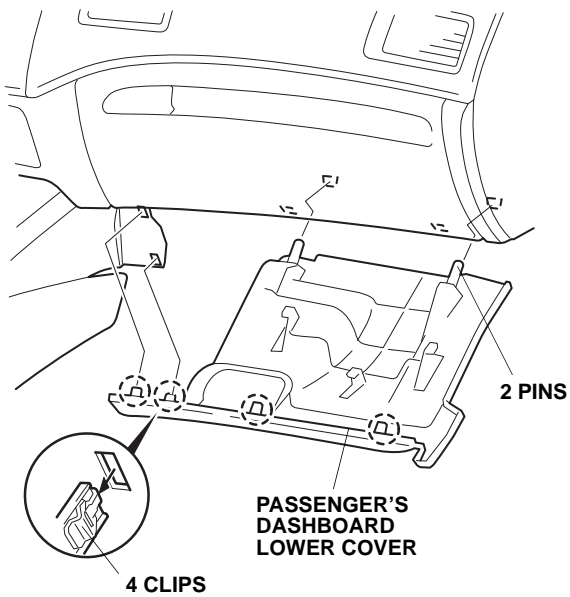

4. Remove the two bolts under the glove box.

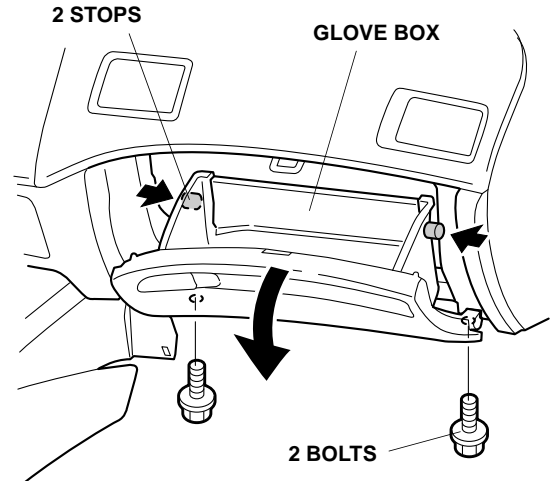

5. Open and remove the glove box (two stops).
6. Remove the driver's dashboard lower cover (eight clips).

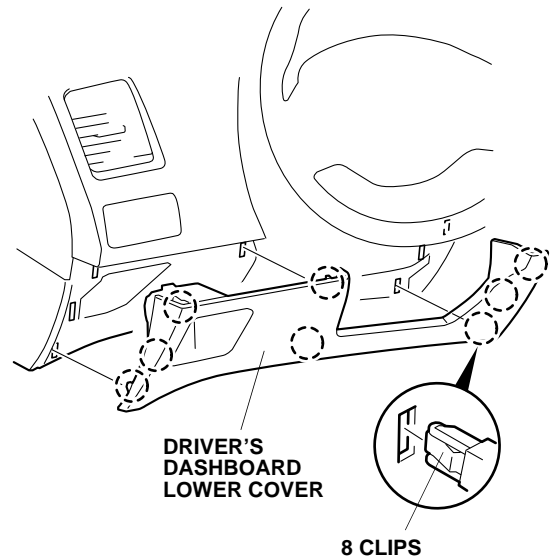

- Remove the inside cover from the front console pocket (two tabs).

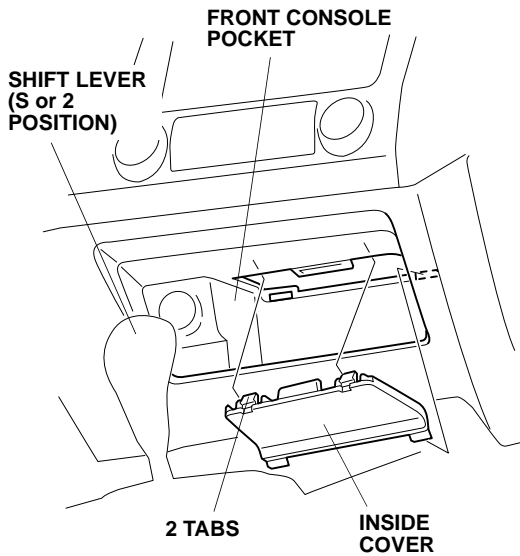

- Lower the tilt lever, then pull the steering wheel toward you.

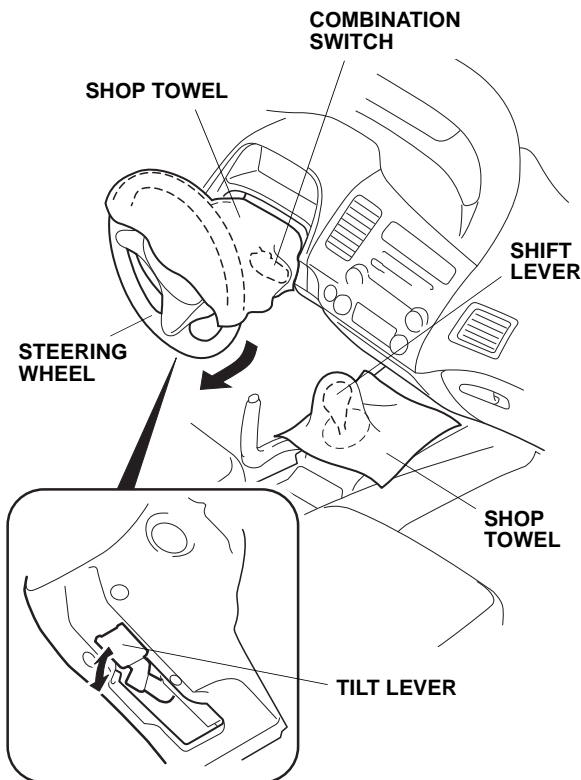

- To protect the dashboard area, put shop towels over the steering wheel and shift lever.

- Apply masking tape to the instrument panel as shown, and remove the meter panel (one self-tapping screw and 11 clips, and unplug the vehicle connectors).

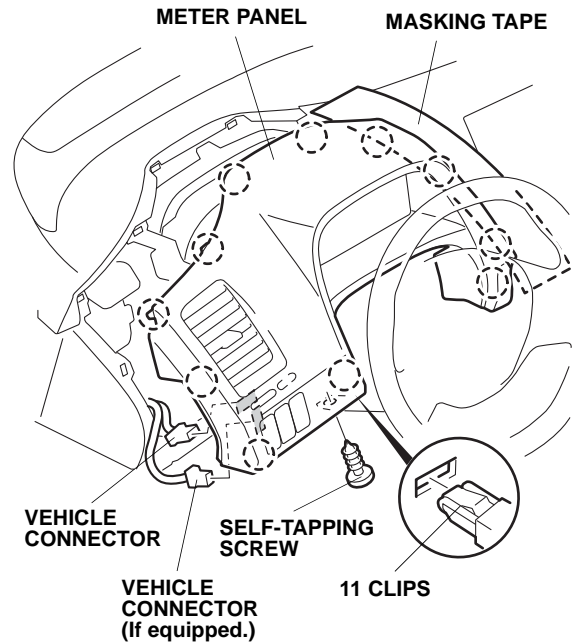

- Pull the aspirator hose off the air conditioner sensor.

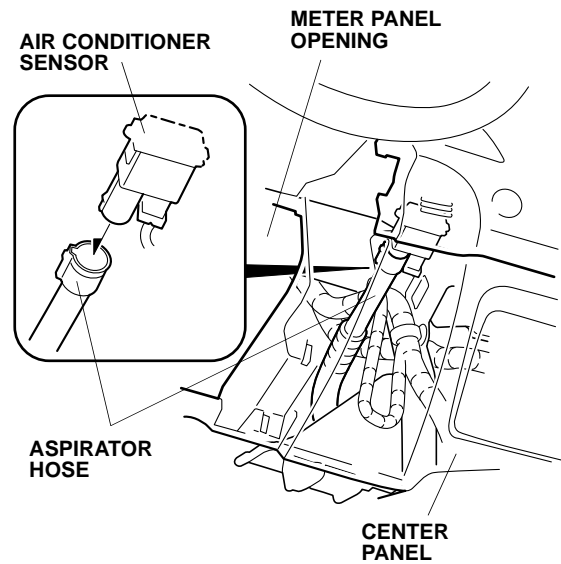

- Apply masking tape to the instrument panel as shown. Remove the center panel (two bolts and 11 clips, and unplug the vehicle connectors).

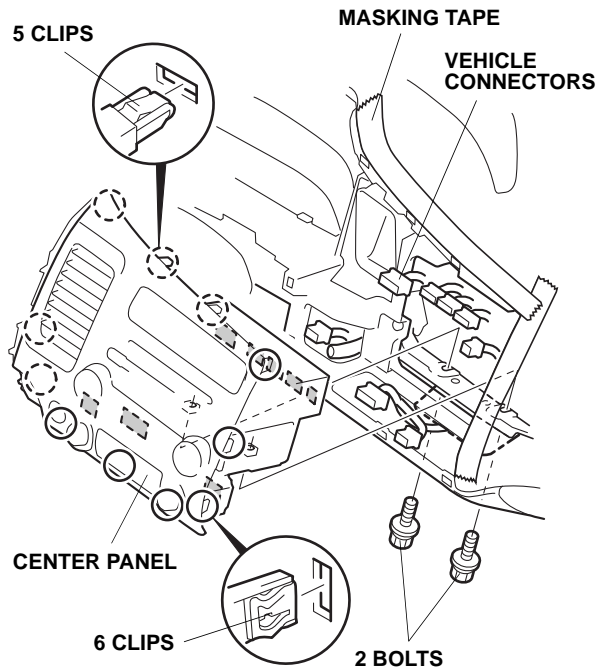

- Pull back the weatherstrip in the area shown.

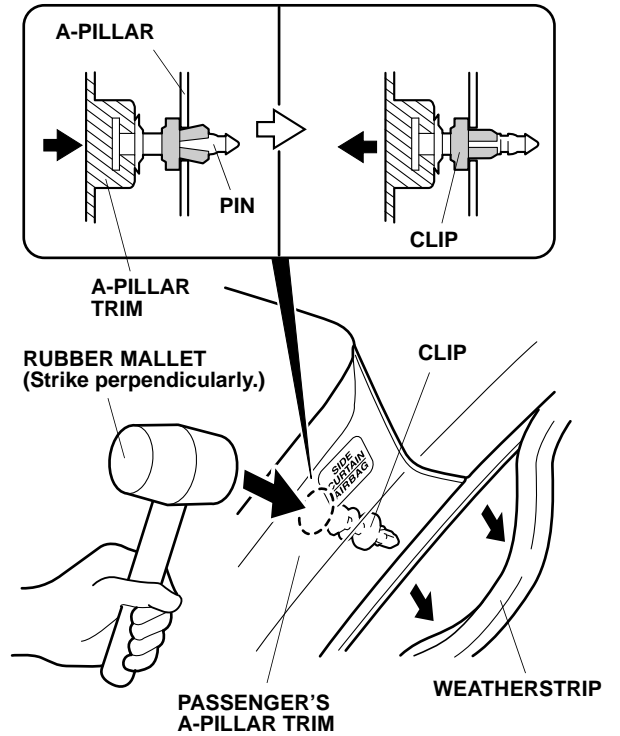

- Push the clip into the vehicle side by striking the top of the passenger's A-pillar trim in the part marked as "SIDE CURTAIN AIRBAG" with a rubber mallet perpendicularly to the vehicle.
- Pull the weatherstrip off in the area shown. Then remove the A-pillar trim (two clips).

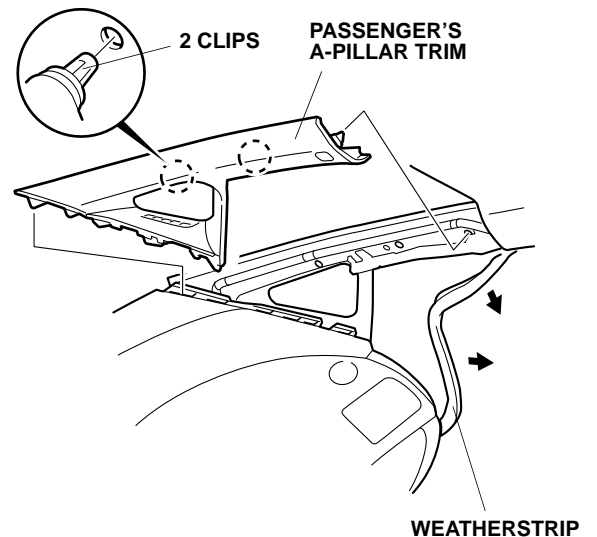

- Remove the cap from the right sunvisor (four retaining tabs).

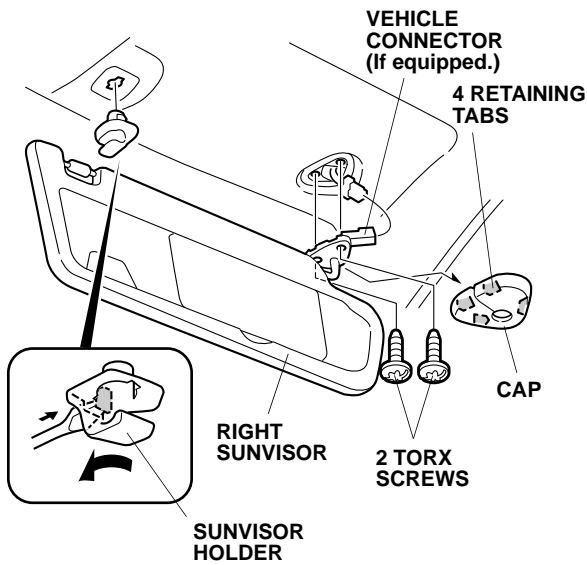

- Remove the right sunvisor (two T25 TORX screws, and unplug the vehicle connector, if equipped).
- Remove the sunvisor holder. Turn the holder 90°, then pull it out.
- Remove the center console cover (five clips).

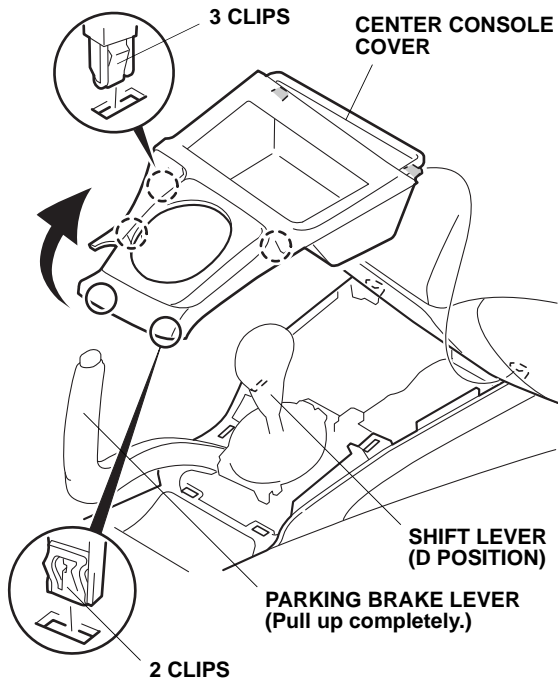

- Open the center console lid, and remove the mat.

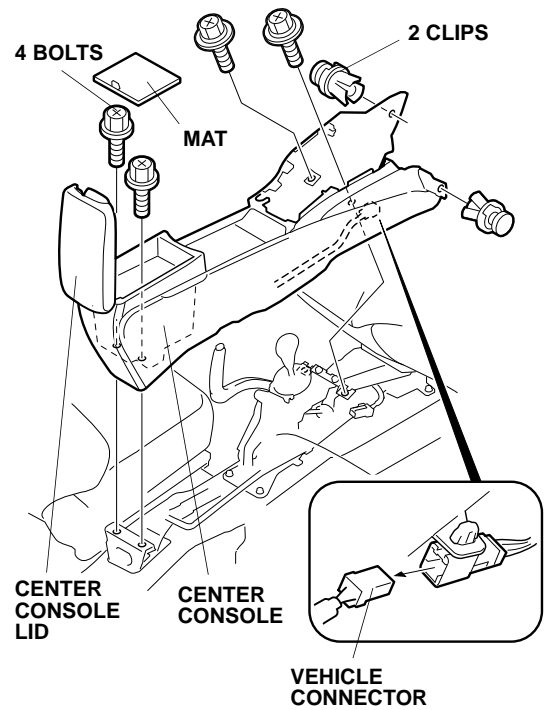

- Remove the center console (four bolts and two clips, and unplug the vehicle connector).
- Remove the rear seat cushion (one bolt and release the two hooks).

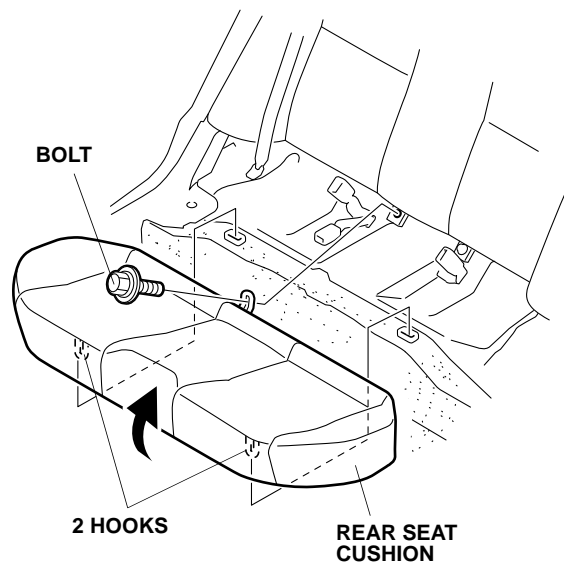

23. Remove the three bolts fastening the rear seat-back and pull the rear seat-back up to release the three hooks. Remove the rear seat-back.

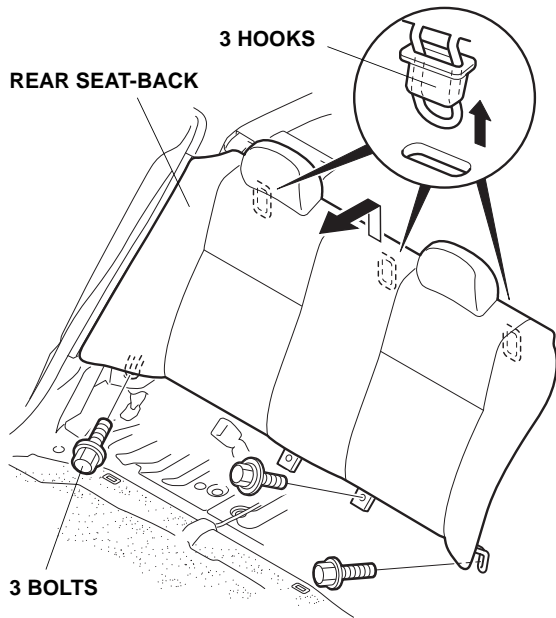

24. Remove the right rear side step trim (four clips and three retaining tabs).

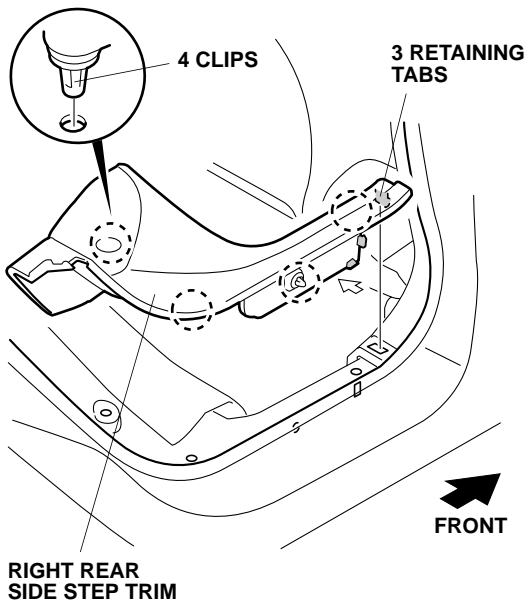

25. Open the trunk lid, and remove the trunk floor mat.

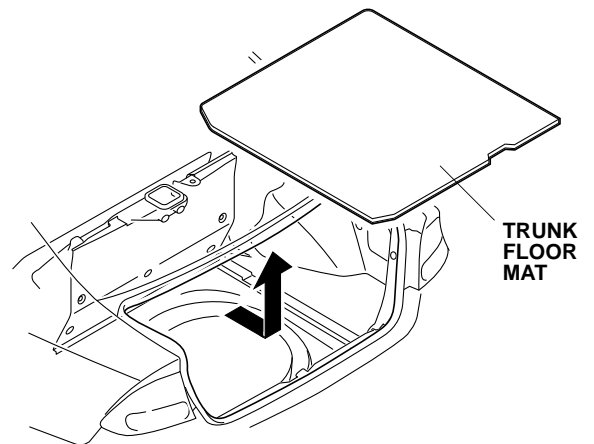

26. Pull back the trunk weatherstrip in the area shown. Remove the rear trim panel (four clips and three hooks).

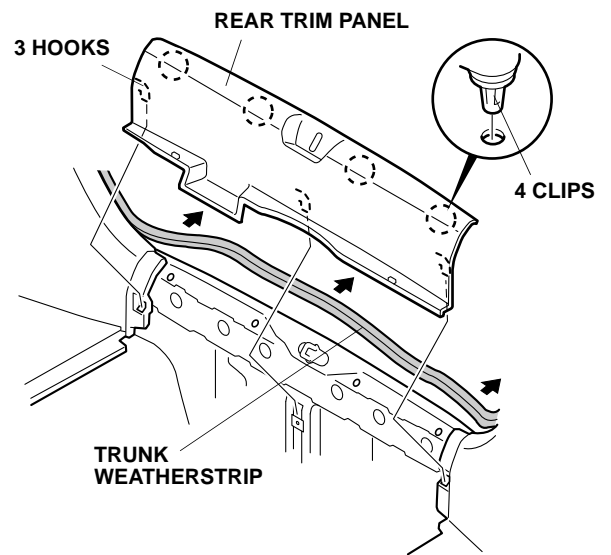

27. Inside the trunk, remove the front trunk lining (six clips).

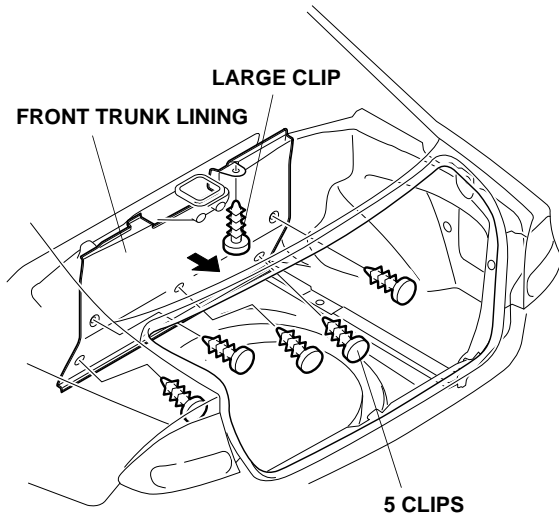

28. Pull back the weatherstrip. Remove the four clips, then pull out the right trunk side trim panel.

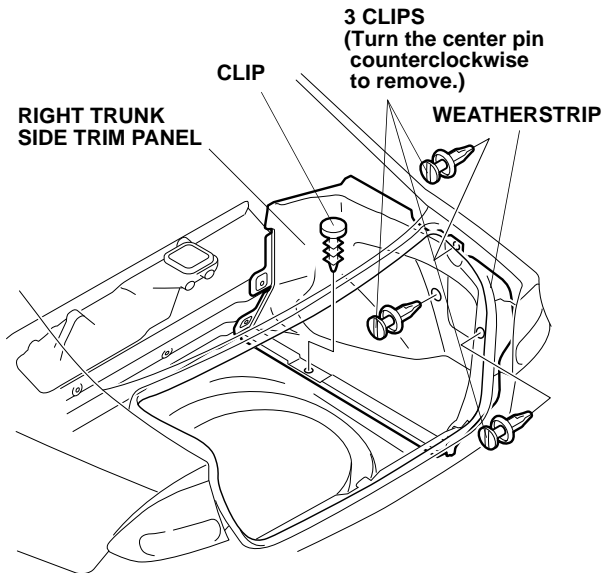

Routing the Bus Cable

29. Route the bus cable from the trunk along the vehicle harness.

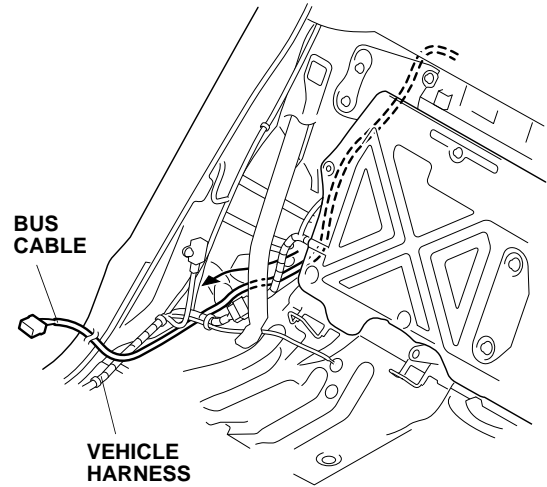

30. Remove the clip that secures the floor carpet. Pull back the floor carpet.

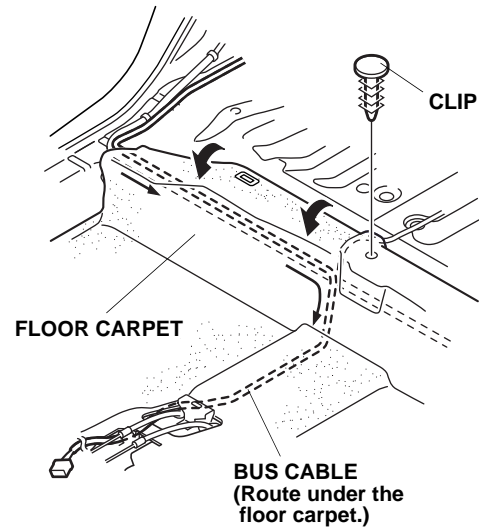

31. Route the bus cable forward under the floor carpet.

32. Route the bus cable forward along the vehicle harness to the right front of the console frame .

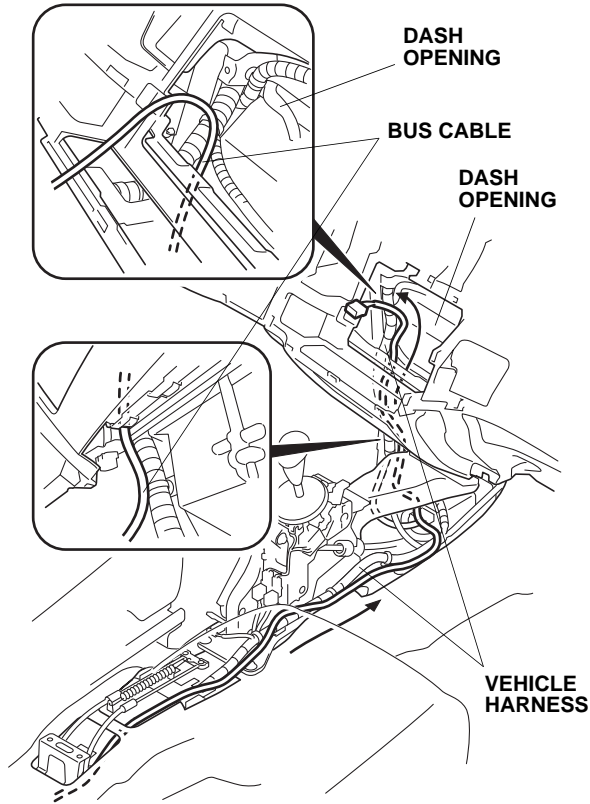

33. Route the bus cable connector to the dashboard and out through the dash opening.

Routing the Antenna Cable

34. Using isopropyl alcohol on a shop towel, clean the area shown on the inside of the windshield.

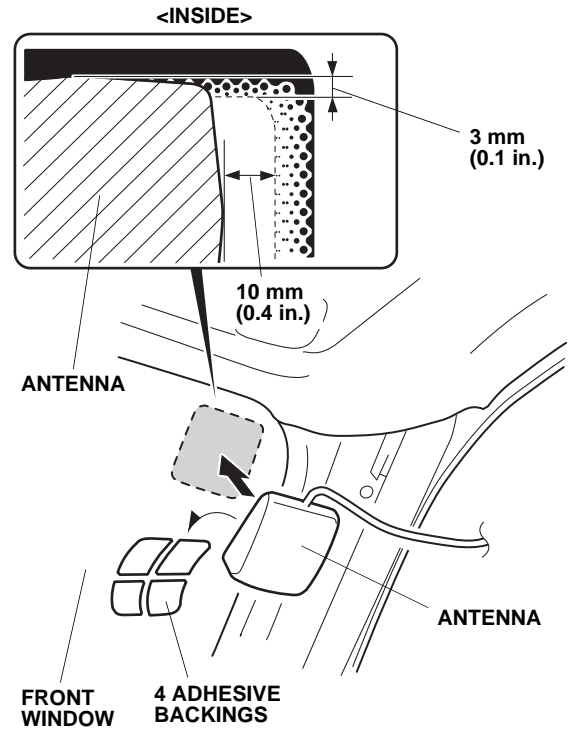

35. Remove the adhesive backings from the antenna, and attach the antenna to the location shown. Apply sufficient pressure so that the antenna adheres completely to the windshield.

36. Attach masking tape to the location shown.

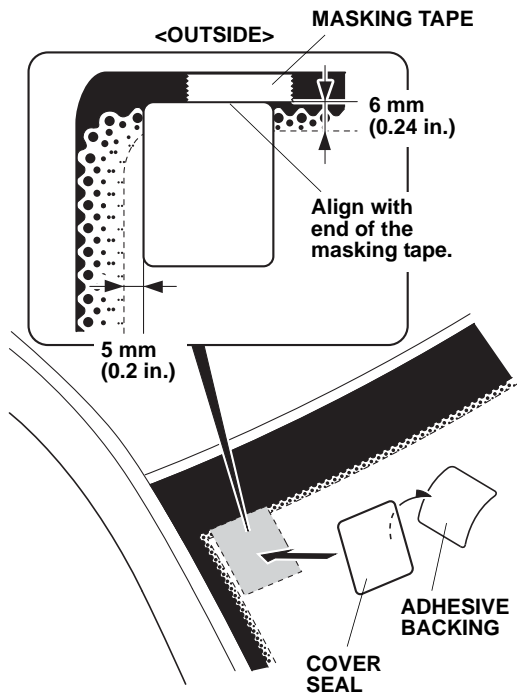

37. With isopropyl alcohol on a shop towel, clean the area shown on the outside of the windshield.
38. Remove the adhesive backing from the cover seal, then attach to the location shown. Remove the masking tape.
39. With scissors, cut three EPT sealers in half.

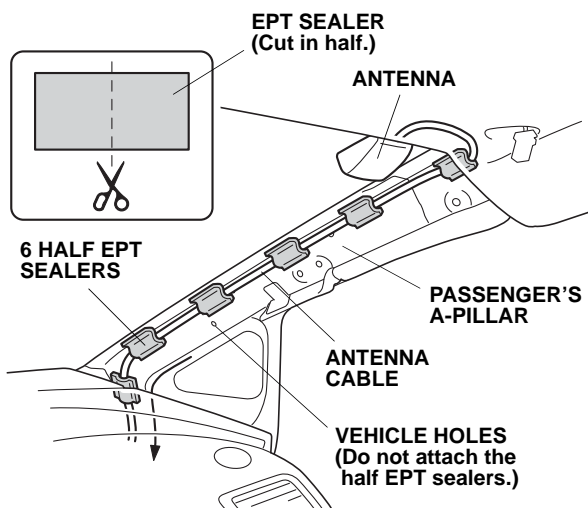

40. Route the antenna cable down along the passenger's A-pillar. Using the six pieces of EPT sealer, secure the antenna cable to the A-pillar panel in the areas shown after cleaning with isopropyl alcohol on a shop towel.

NOTE: Do not attach the half EPT sealers to the vehicle holes, pay attention to the orientation of the half EPT sealers.

41. Clean the vehicle bracket shown with isopropyl alcohol on a shop towel, then attach one EPT sealer to the bracket.

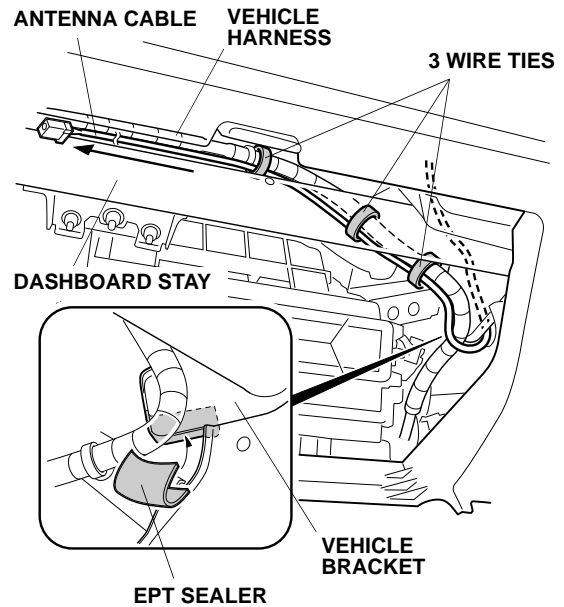

42. Route the antenna cable down behind the dashboard stay and toward the glove box. Using three wire ties, secure the antenna cable to the vehicle harness.

43. In the glove box opening, route the antenna cable along the vehicle harness and toward the audio unit opening. Secure the antenna cable to the vehicle harness with one wire tie in the area shown.

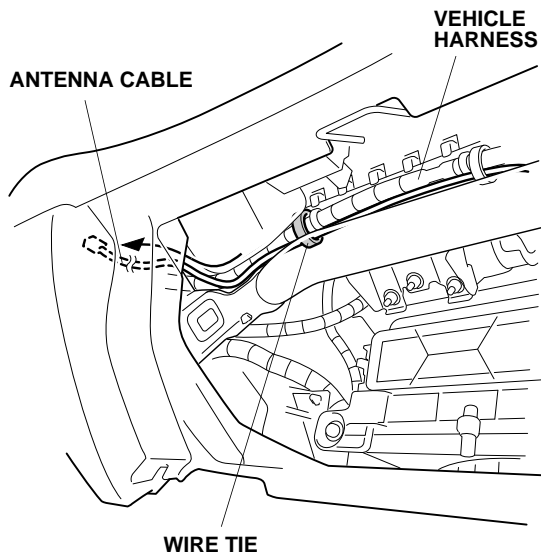

44. Route the antenna cable down along the bus cable as shown.

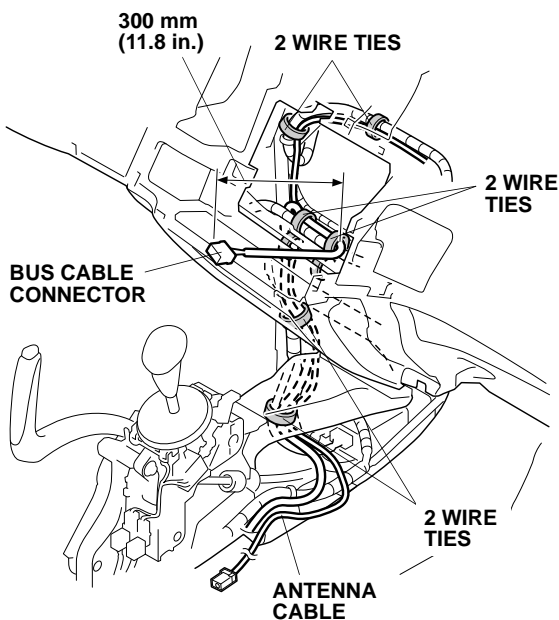

45. Measure 300 mm (11.8 in.) from the end of the bus cable connector, then secure the bus cable and antenna cable to the vehicle harness with six wire ties.

46. Route the antenna cable along the bus cable, secure the bus cable and antenna cable to the vehicle harness with four wire ties.

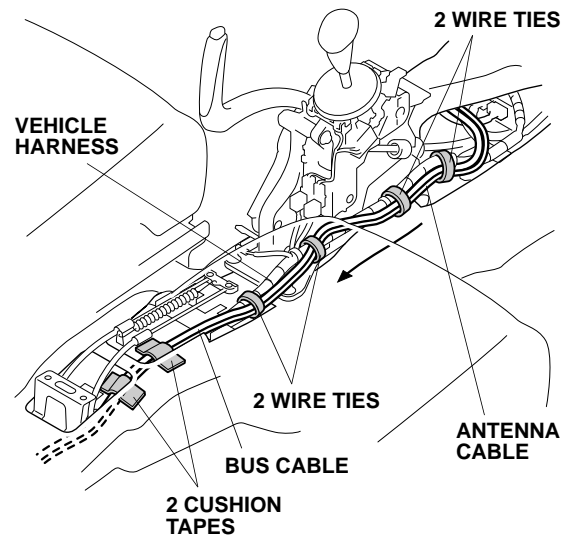

47. Using isopropyl alcohol on a shop towel, clean the area where the cushion tape will attach. Attach the bus cable and antenna cable to the floor panel with the two cushion tapes in the area shown.

48. Route the antenna cable along the bus cable, turn over the floor carpet, then attach the bus cable and antenna cable to the floor panel with the two cushion tapes in the areas shown after cleaning with isopropyl alcohol on a shop towel.

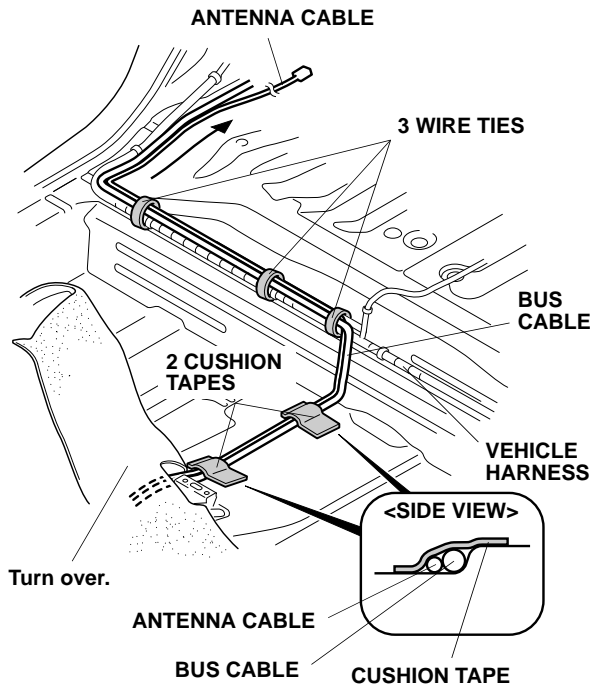

49. Secure the bus cable and antenna cable to the vehicle harness with the three wire ties in the areas shown.

50. Route the antenna cable along the bus cable, secure the bus cable and antenna cable to the vehicle harness with the two wire ties in the areas shown.

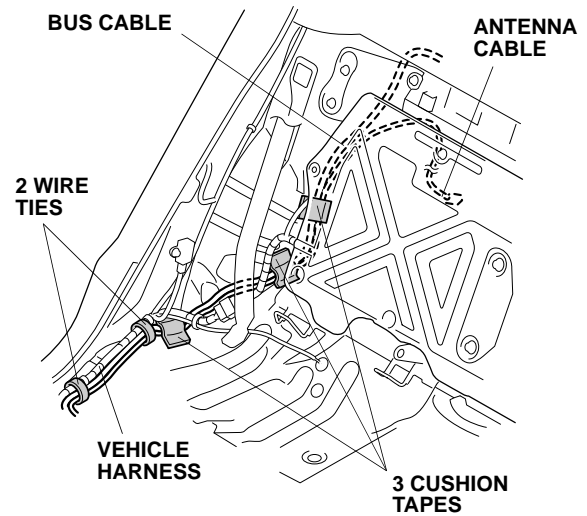

51. Attach the bus cable and antenna cable to the floor panel with the three cushion tapes in the areas shown after cleaning with isopropyl alcohol on a shop towel.

Installing the XM Radio Unit

52. Using four pan screws and four washers, install the front and rear brackets to the XM radio unit.

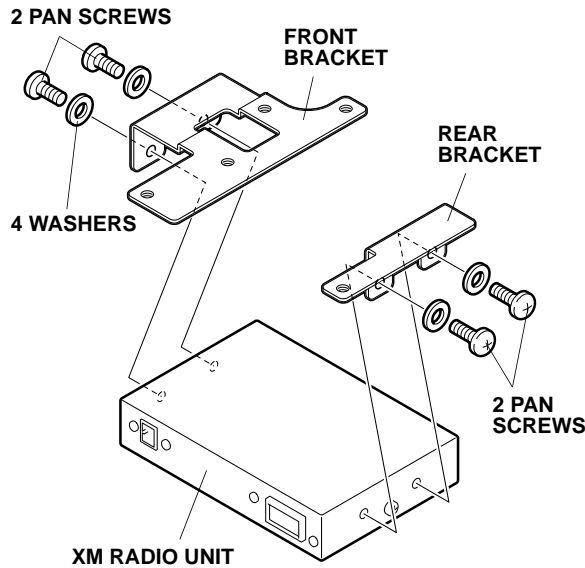

53. With isopropyl alcohol on a shop towel, clean the trunk right inner panel in the area shown.

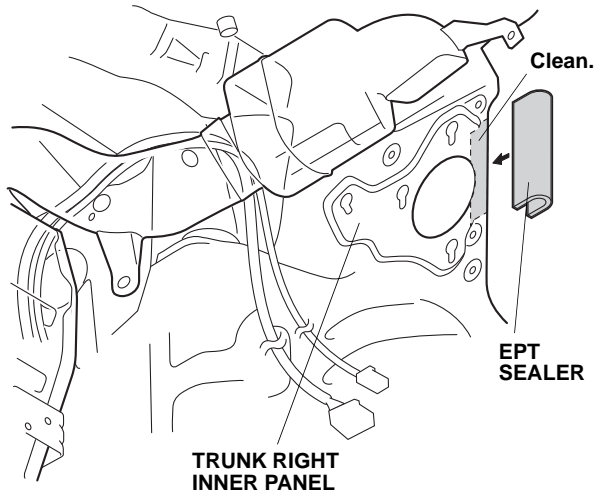

54. Attach one EPT sealer to the trunk right inner panel as shown.

55. Plug the bus cable connector and the antenna cable connector in the XM radio unit.

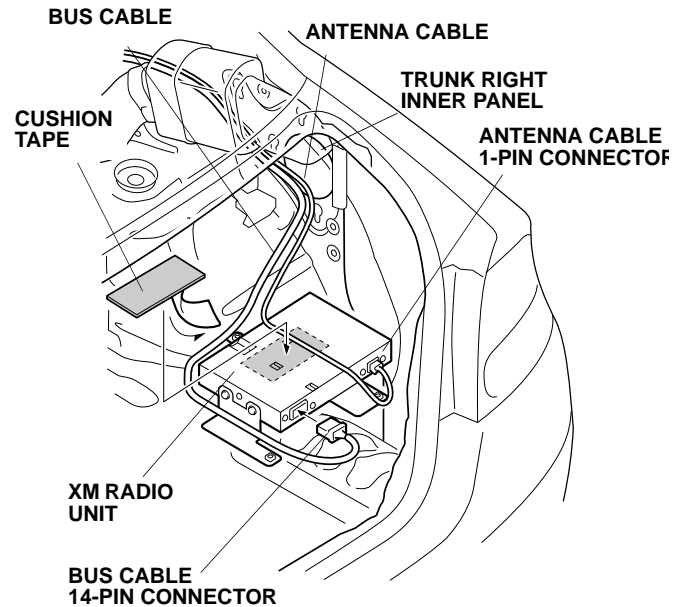

56. Using one cushion tape, secure the antenna cable to the XM radio unit in the area shown after cleaning with isopropyl alcohol.
57. Loosely tighten three flange bolts to the front and rear brackets. On the front bracket, use the "A"-marked holes.

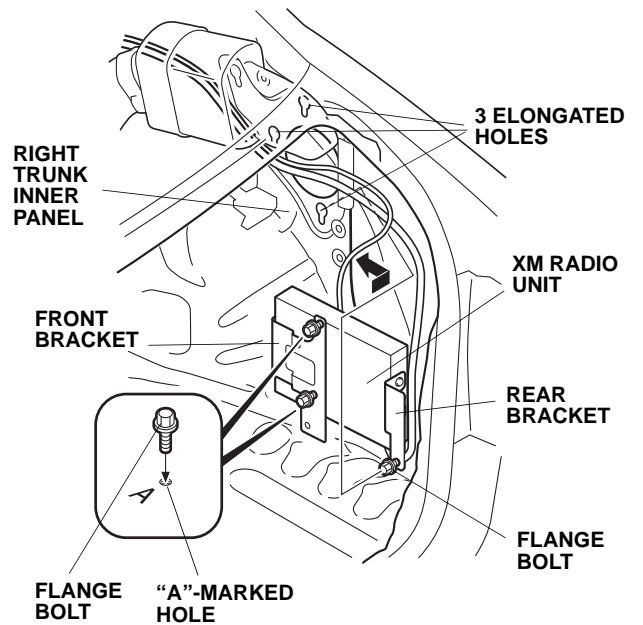

58. Place the XM radio assembly to the back of the trunk right inner panel. Set three flange bolts into the elongated holes in the body panel.
59. Tighten the three flange bolts.

60. Using three wire ties with clips, secure the bus and antenna cables in the areas shown.

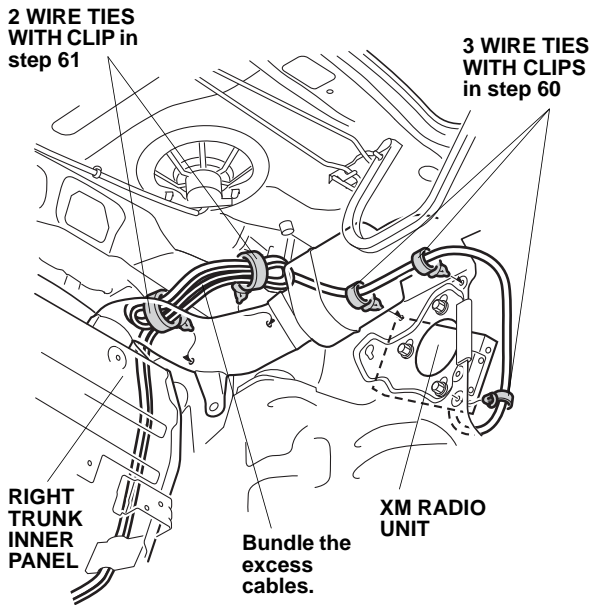

61. Using two wire ties with clips, bundle the excess of the bus and antenna cables to the holes on the right trunk inner panel.

If the vehicle you're working on is equipped with a CD Changer, go on to step 62; otherwise, go to step 64.

62. Plug the 2-port bus cable connectors into the two bus cables.

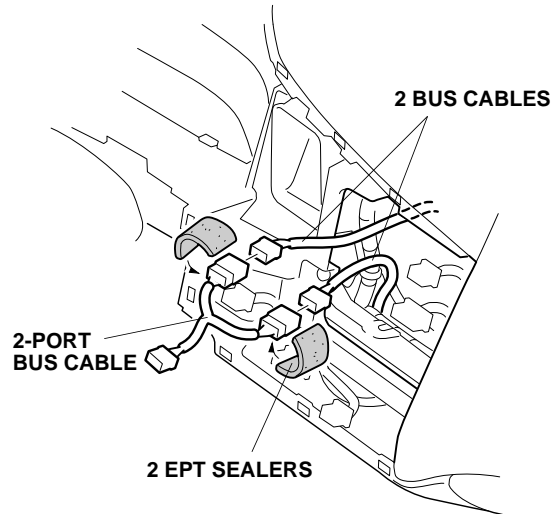

63. Wrap the two plugged connectors using two EPT sealers.
64. Plug the bus cable connector into the audio unit.

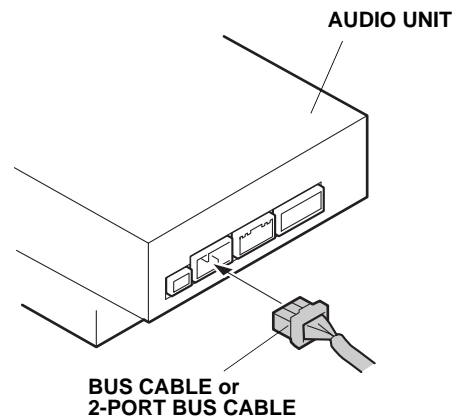

65. Plug the vehicle connectors to the center panel, and reinstall the center panel.

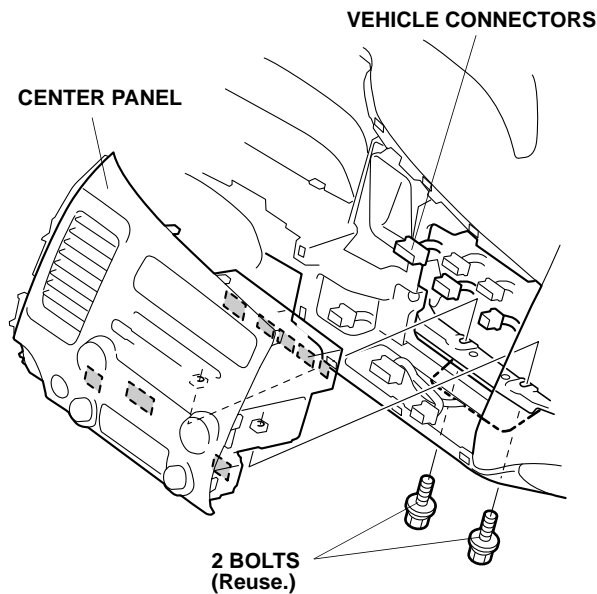

66. Replace the old clip on the right front pillar trim with a new one.

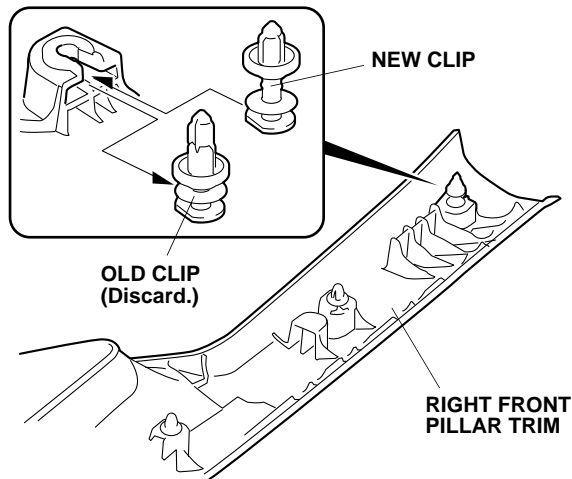

67. Check that all wire harnesses are routed properly and all connectors are plugged in.
68. Reinstall all removed parts.
69. Connect the negative cable to the battery and check operation of all lights and other electrical accessories.
70. Enter the anti-theft codes for the audio system and the navigation system (if equipped), and reset the radio station presets.
71. Reset the clock on vehicles without navigation.
72. Check the operation of the XM radio system.
73. If the IMA battery level gauge (BAT) displays zero segments, start the engine, and hold it between 3,500 and 4,000 rpm (in Park or Neutral) until the gauge displays at least three segments.
74. Initialize the auto up/down feature for the front windows.