



# INSTALLATION INSTRUCTIONS

Accessory

**XM RADIO SYSTEM**

Application

**2007 CIVIC  
(Hybrid)**

Publications No.

**All 33761**

Issue Date

**SEP 2006**

## PARTS LIST

**XM Radio Attachment (sold separately):  
P/N 08B15-SNA-100B**

Bus cable

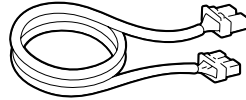

Front bracket

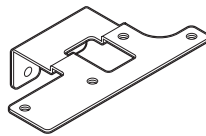

Rear bracket

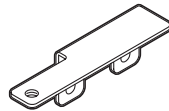

Clip



4 Pan screws



4 Washers



3 Flange bolts



Cover seal

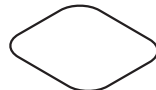

20 Wire ties

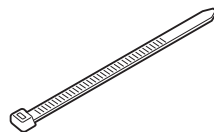

7 Wire ties with clip

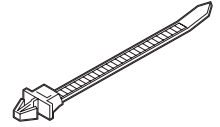

12 Cushion tapes



8 EPT sealers

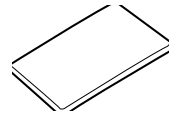

**XM Antenna (sold separately):  
P/N 08A15-0J1-100**

Antenna assembly

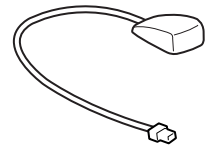

**Unit (sold separately):  
P/N 08A15-3J1-000**

XM radio unit

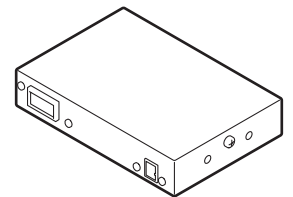

**2-Port Bus Cable (sold separately):  
P/N 08A31-0F1-000**

2-Port bus cable

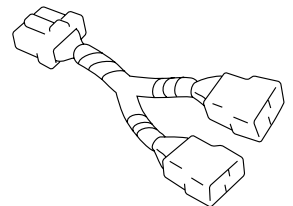

## TOOLS AND SUPPLIES REQUIRED

Phillips screwdriver  
Flat-tip screwdriver  
Utility knife  
Ruler  
Shop towel  
Scissors  
Ratchet  
8 mm, 10 mm and 14 mm Sockets  
8 mm, 10 mm and 14 mm Combination wrenches  
Isopropyl alcohol  
Rubber mallet  
Duct tape  
TORX bit

## Illustration of the XM Radio System Installed on the Vehicle

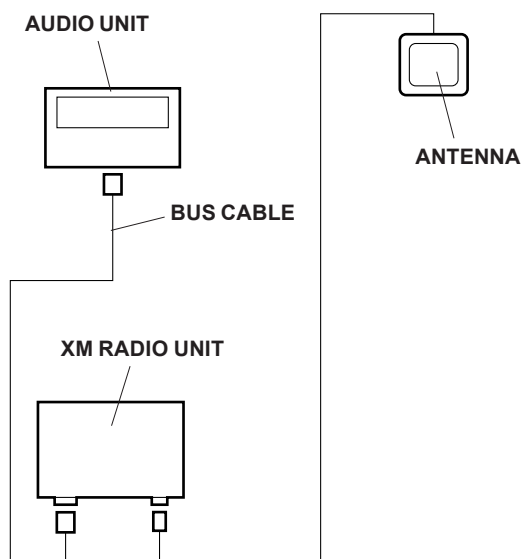
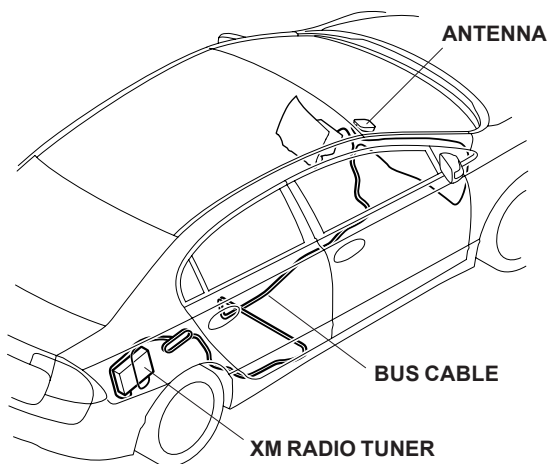

## INSTALLATION

**Customer Information:** The information in this installation instruction is intended for use only by skilled technicians who have the proper tools, equipment, and training to correctly and safely add equipment to your vehicle. These procedures should not be attempted by "do-it-yourselfers."

1. Make sure you have the anti-theft code for the radio, then write down the frequencies for the preset buttons.
2. Disconnect the negative cable from the battery.
3. Remove the passenger's dashboard lower cover (four clips, and two pins).

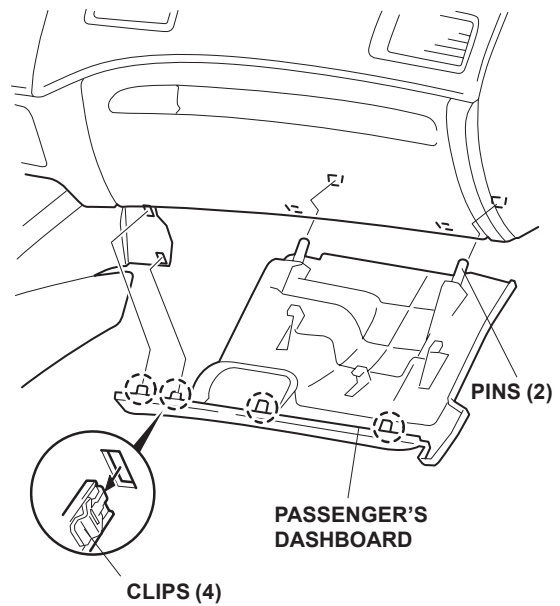

- Remove the two bolts under the glove box.

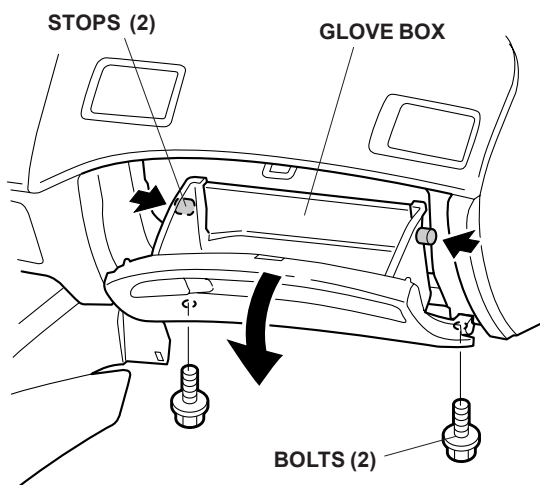

- Open the glove box. Release the stops and remove the glove box.
- Remove the driver's dashboard lower cover (eight clips).

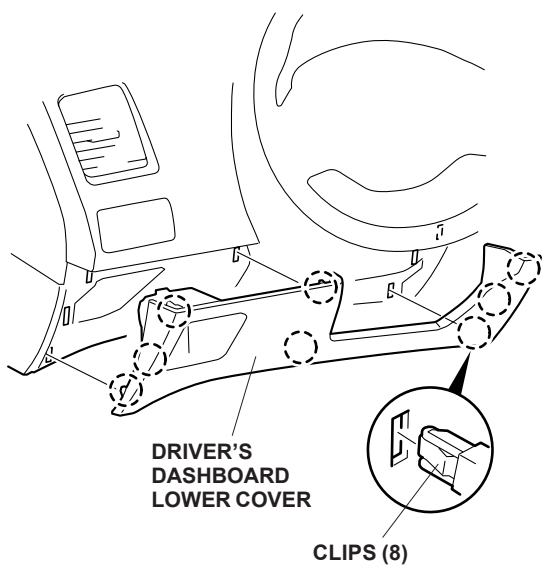

- Remove the inside cover from the front console pocket (two tabs).

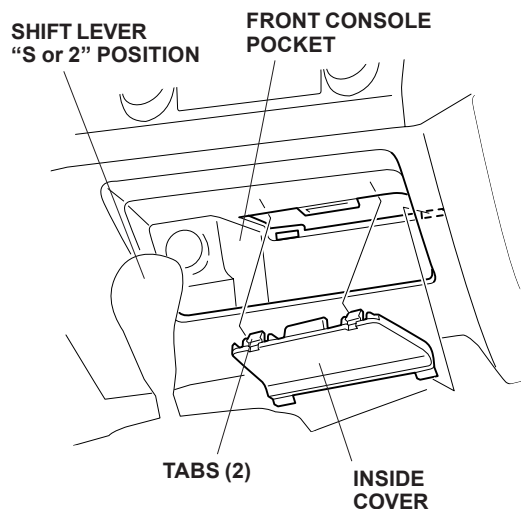

- Lower the tilt lever and pull the steering wheel toward you.

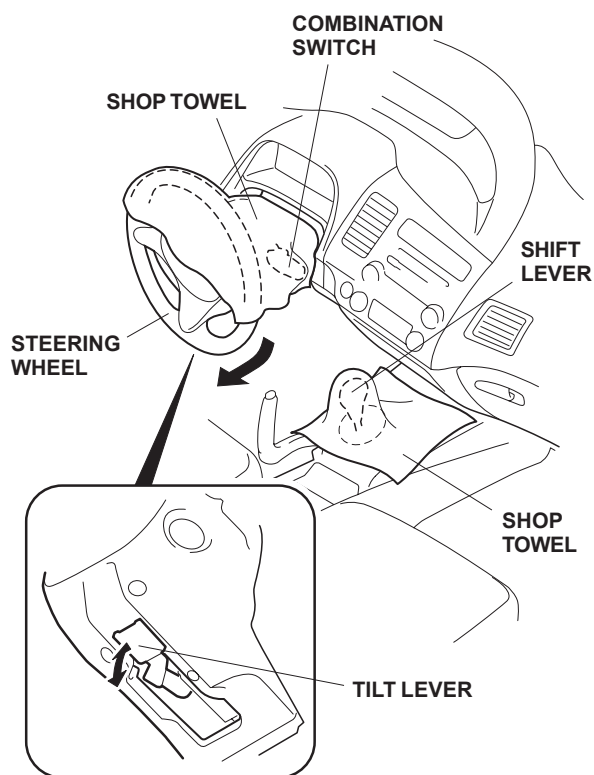

- To protect the dashboard area, place shop towels over the steering wheel and shift lever.

10. Apply masking tape to the meter panel as shown, and remove the instrument panel (one self-tapping screw, 11 clips, and two connectors).

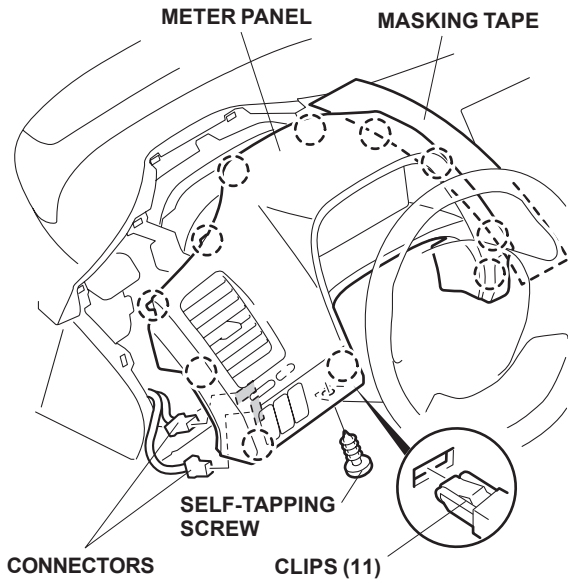

11. Pull the aspirator hose off the air conditioner sensor.

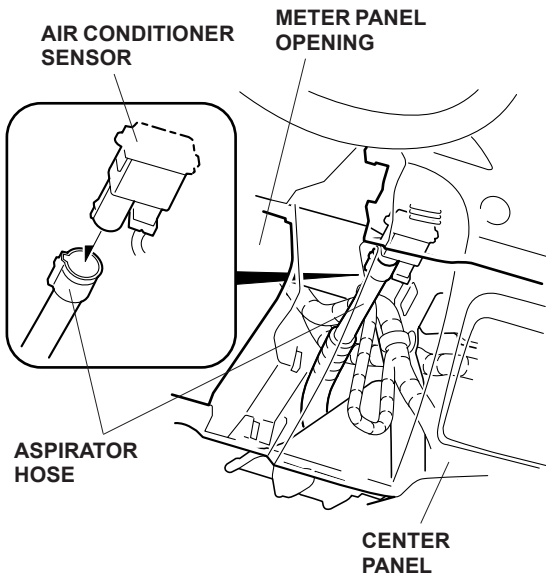

12. Apply duct tape to the instrument panel as shown, and remove the center panel (two bolts, 11 retaining clips, and two vehicle connectors).

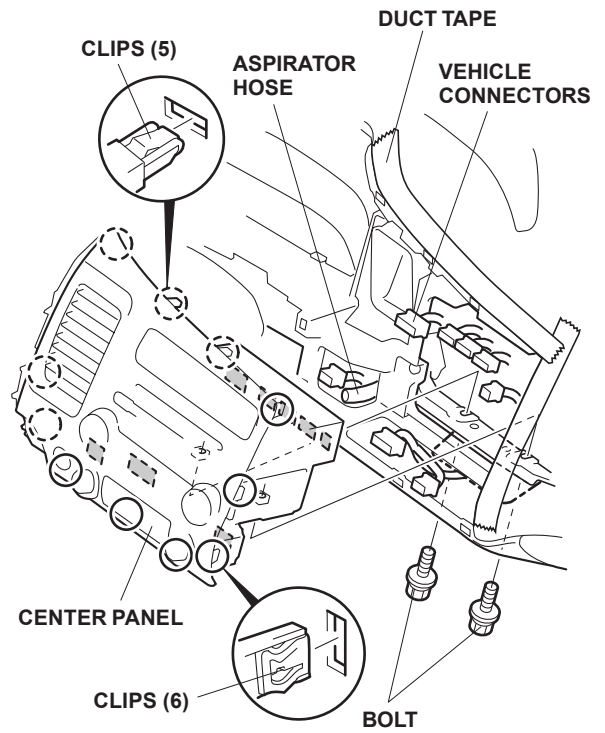

- Remove the weatherstrip from the opening edge of the right front pillar in the area shown.

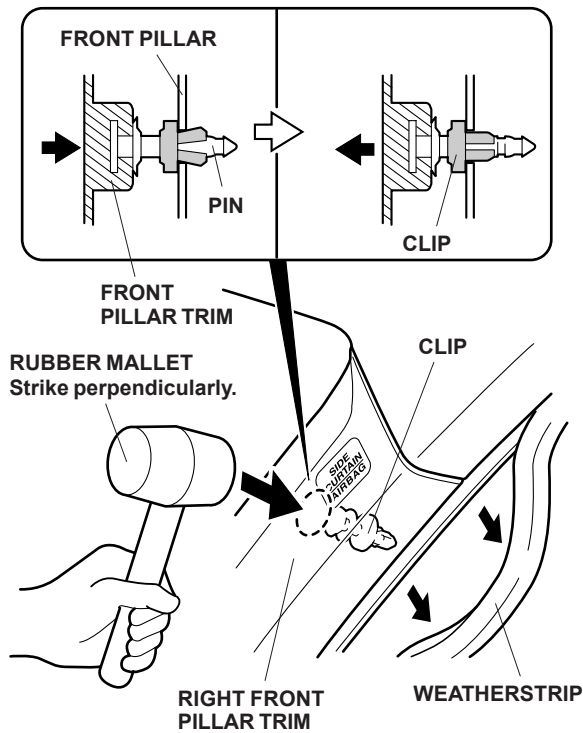

- Push the clip into the vehicle side by striking the top of the right front pillar trim on the part marked "SIDE CURTAIN AIRBAG" with the rubber mallet. Then remove the clip.
- Remove the weatherstrip in the area shown. Remove the right front pillar trim (two clips).

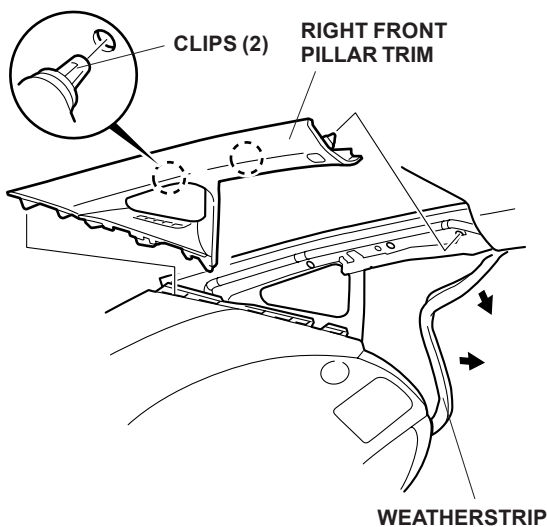

- Remove the cap from the right sunvisor (four retaining tabs).

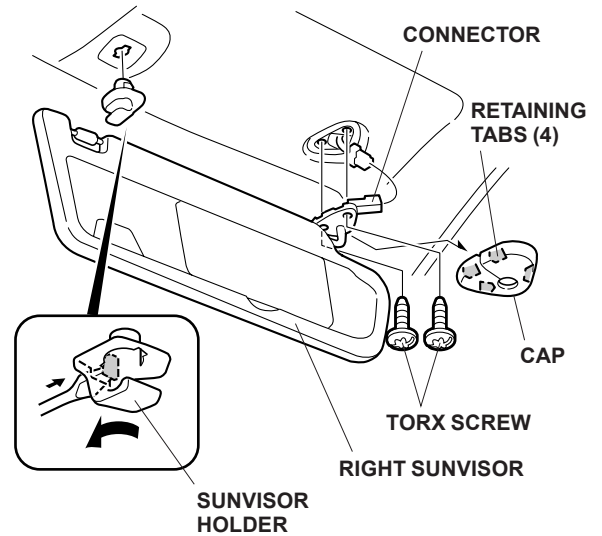

- Remove the right sunvisor (two T25 Torx screws, and unplug the vehicle connectors).
- Remove the sunvisor holder. Turn the holder 90°, then pull it out.
- Pull up the parking break lever, and remove the center console cover (five clips).

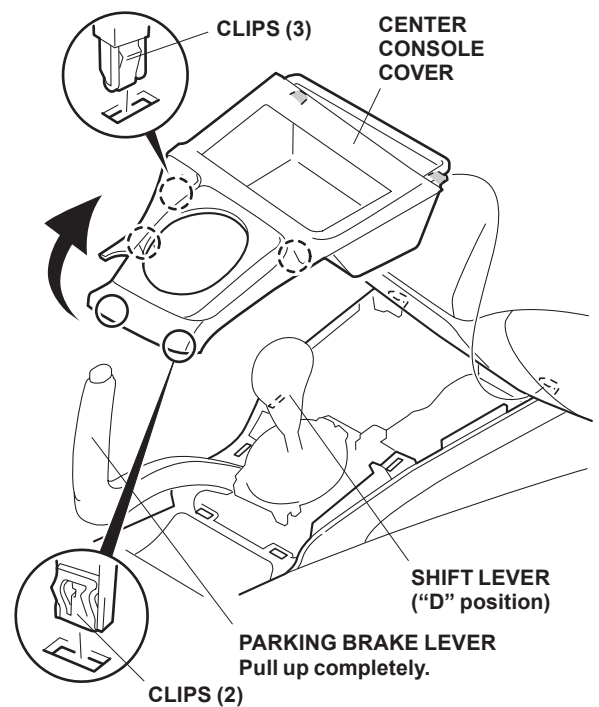

20. Open the center console lid, and remove the mat.

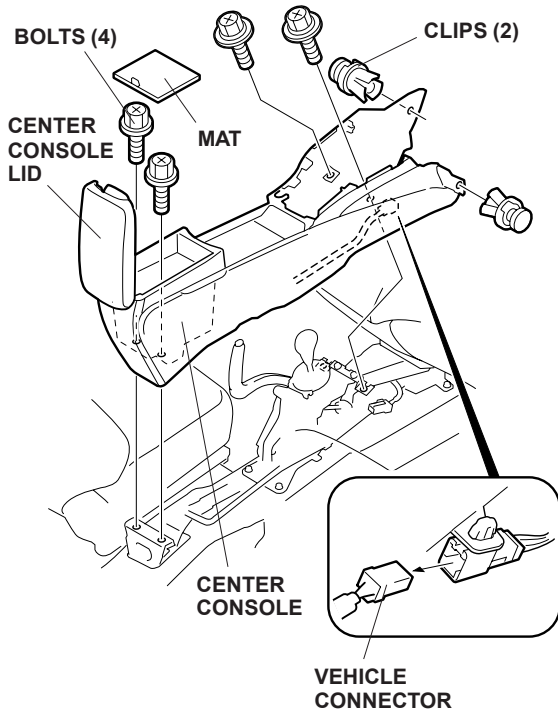

21. Remove the center console (four bolts, two clips, and one vehicle connector).

22. Remove the rear seat cushion (one bolt and release the two hooks).

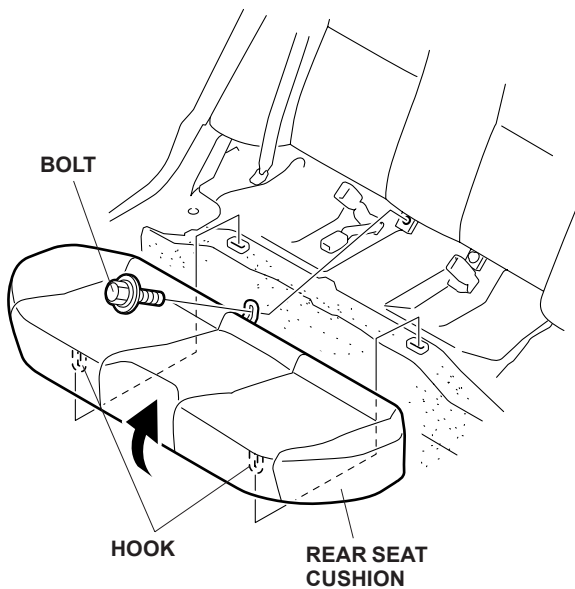

23. Remove the three bolts fastening the rear seat back and pull the rear seat back up to release the three hooks. Remove the rear seat back.

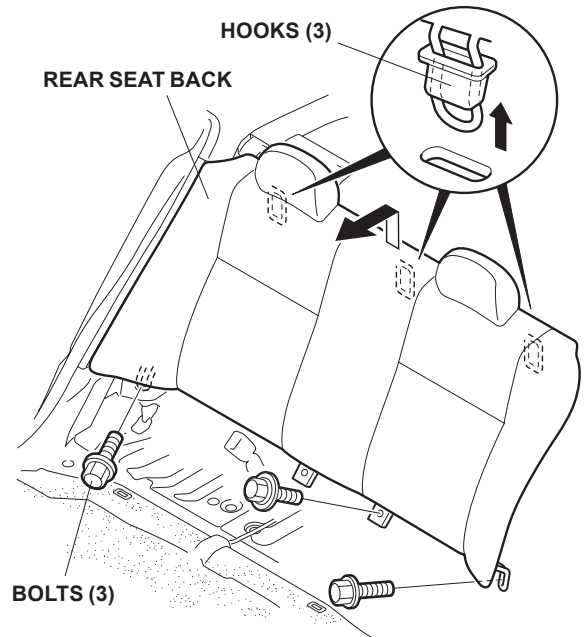

24. Remove the right rear side step trim (four clips and three retaining tabs).

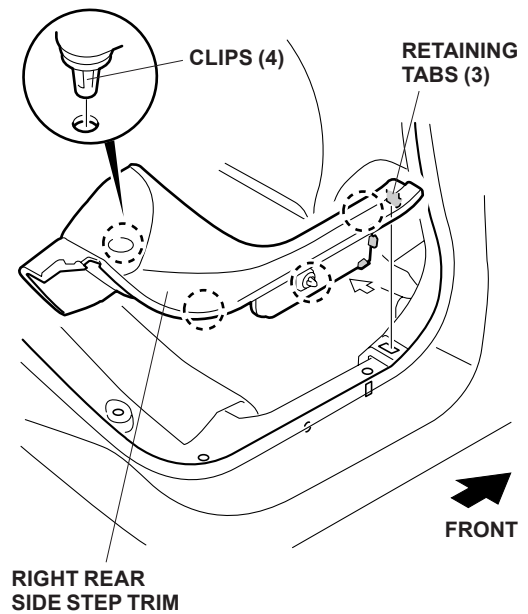

25. Open the trunk lid, and remove the trunk floor mat.

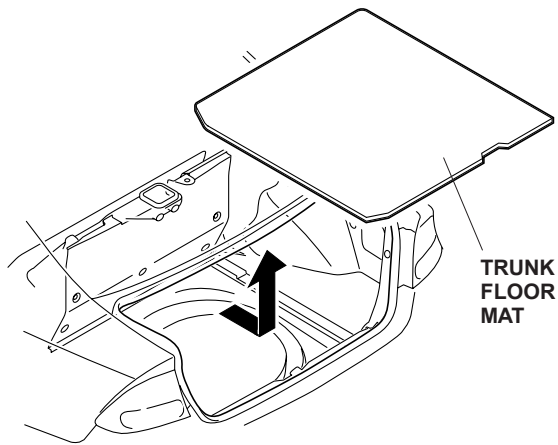

26. Remove the trunk weatherstrip off in the area shown.

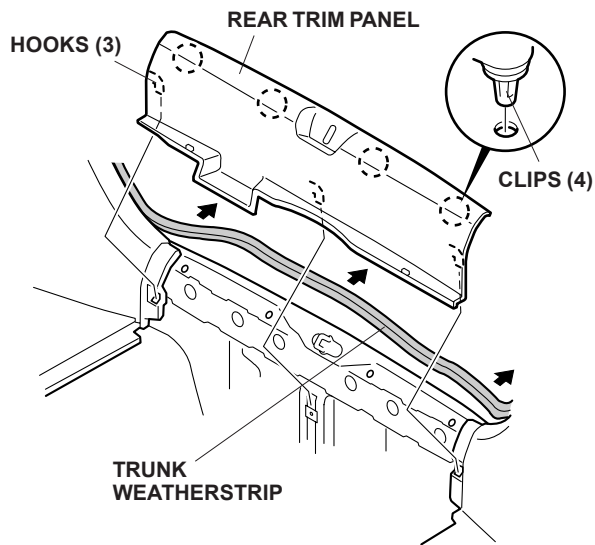

27. Inside the trunk, remove the trunk front lining (six clips).

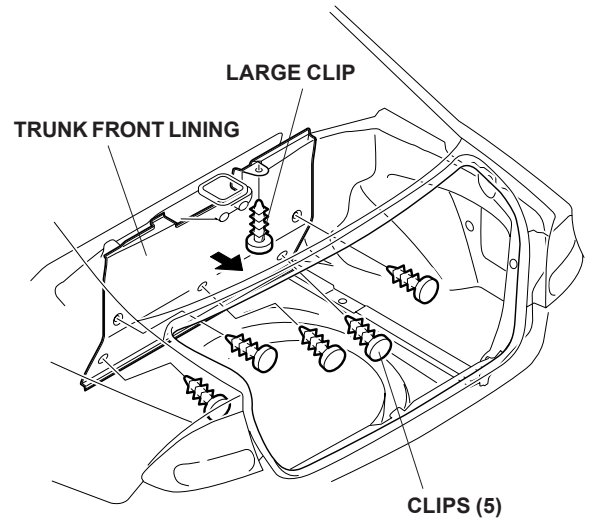

28. Pull the weatherstrip off. Remove the five clips, then pull out the right trunk side trim panel.

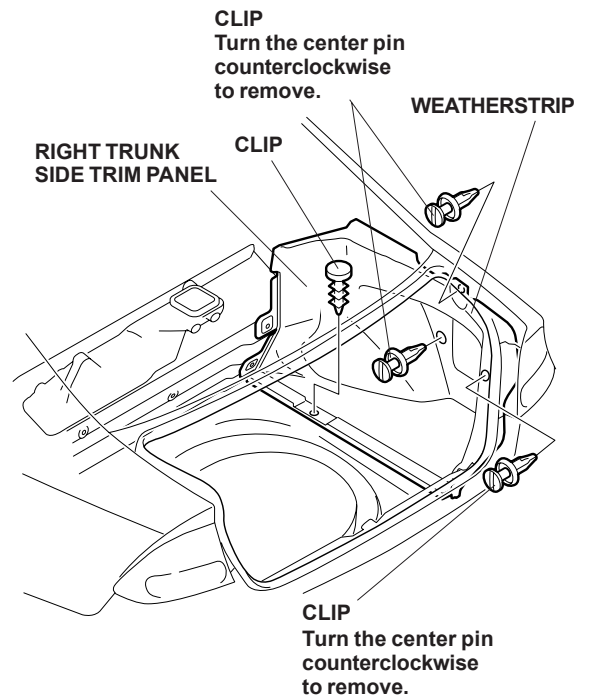

## Routing the Bus Cable

29. Route the Bus cable from the trunk along the vehicle harness, then remove the clip that secures the floor carpet. Pull back the floor carpet.

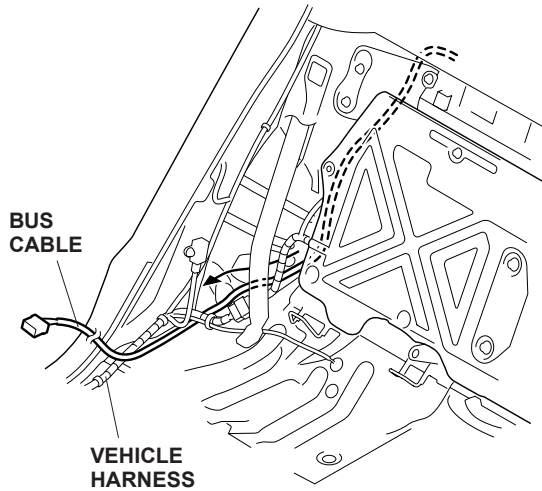

30. Route the bus cable forward under the floor carpet.

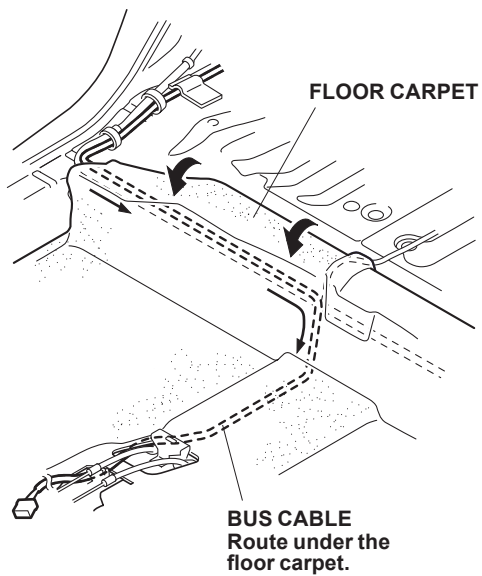

31. Route the Bus cable forward along the vehicle harness to the right front console frame.

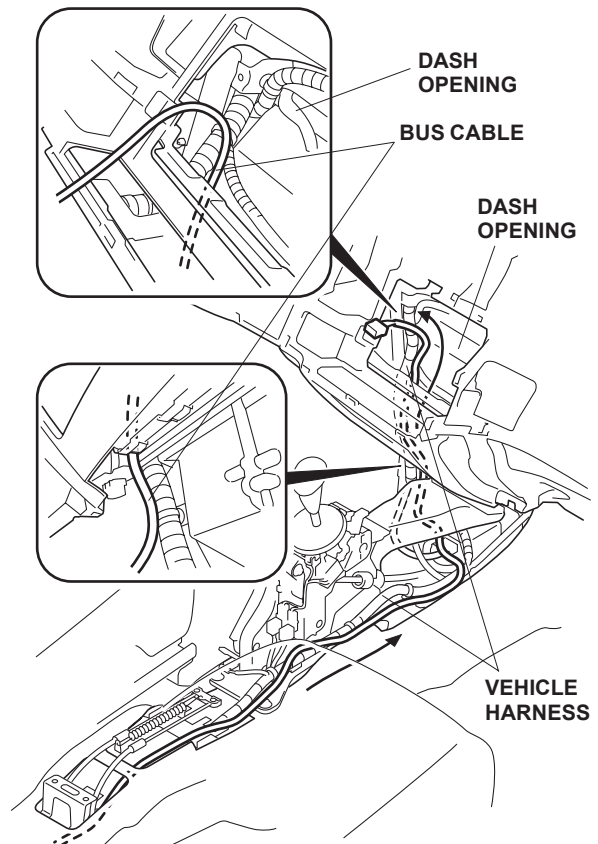

32. Route the Bus cable connector to the dashboard and out through the dash opening.



### Routing the Antenna Cable

33. Using isopropyl alcohol on a shop towel, clean the area shown on the inside of the windshield.

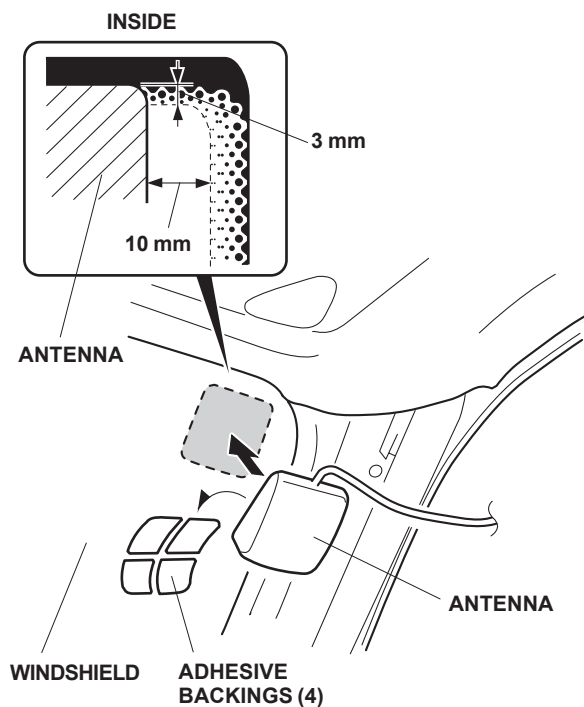

34. Remove the adhesive backings from the antenna, and attach the antenna to the windshield at the location shown. Install the antenna by applying sufficient pressure.

35. Using isopropyl alcohol on a shop towel, clean the area shown on the outside of the windshield. Remove the adhesive backing from the cover seal, to attach it in the location shown.

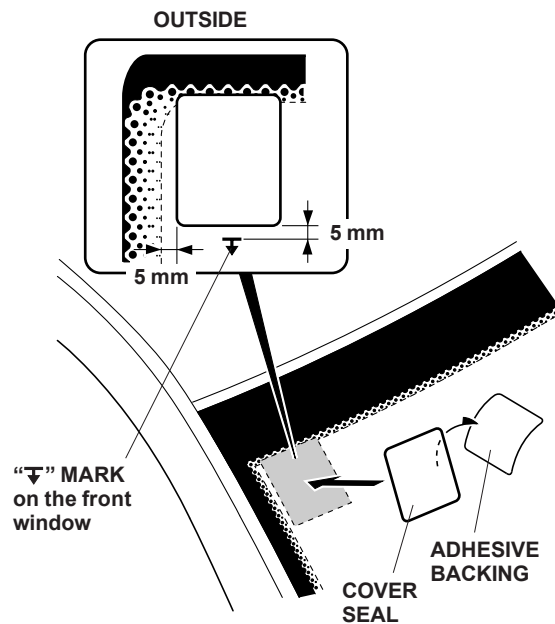

36. With scissors, cut three EPT sealers in half.

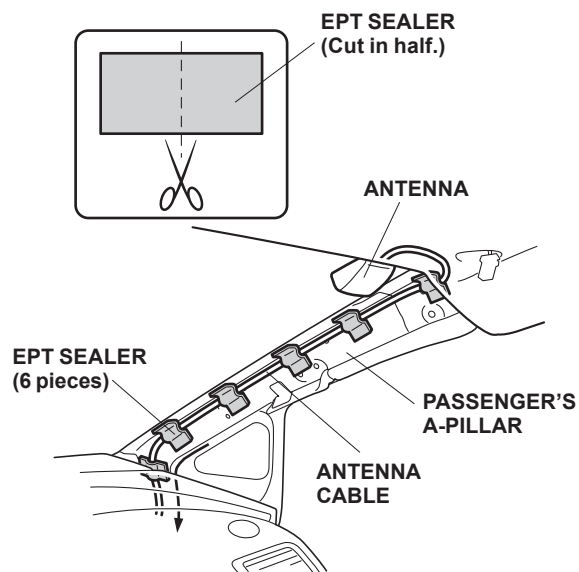

37. Route the antenna cable down along the passenger's A-pillar. Using six cut pieces of EPT sealer, secure the antenna cable to the A-pillar panel in the areas shown.

38. Using isopropyl alcohol on a shop towel, clean the area where the EPT sealer will attach. Attach one EPT sealer to the vehicle bracket as shown.

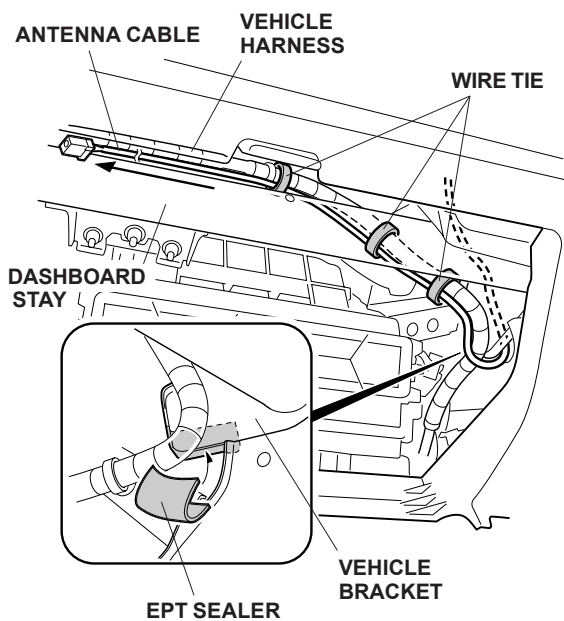

39. Route the antenna cable down behind the dashboard stay and towards the glove box. Using three wire ties, secure the antenna cable to the vehicle harness.
40. In the glove box opening, route the antenna cable along the vehicle harness and towards the audio unit opening. Secure the antenna cable to the vehicle harness with one wire tie in the area shown.

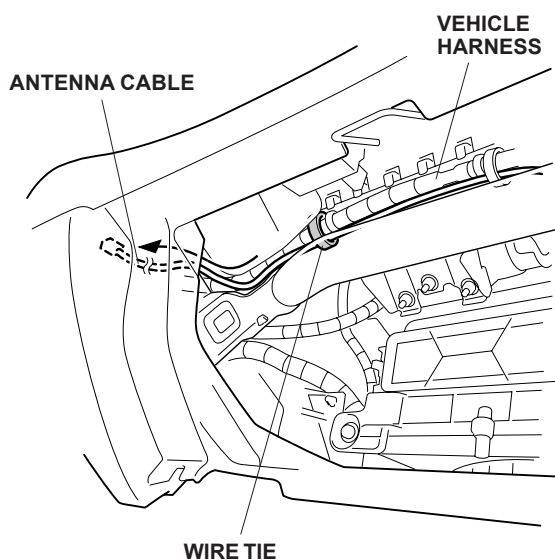

41. Route the antenna cable down along the Bus cable as shown.

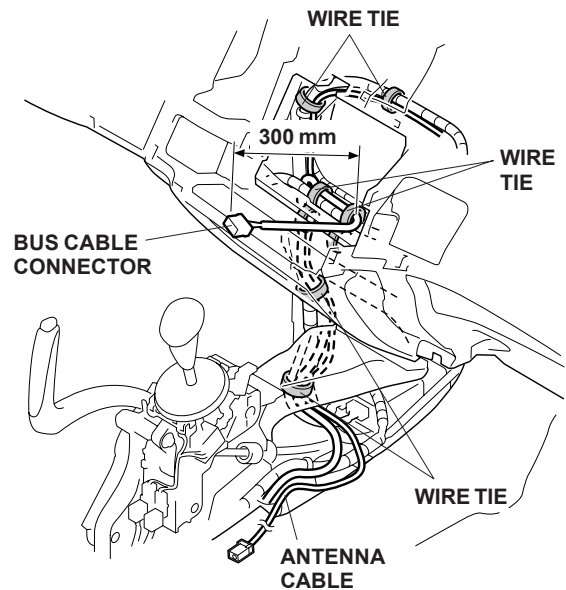

42. Measure 300 mm from the end of the Bus cable connector, then secure the Bus cable and antenna cable to the vehicle harness with six wire ties.
43. Route the antenna cable along the Bus cable, secure the Bus cable and antenna cable to the vehicle harness with three wire ties.

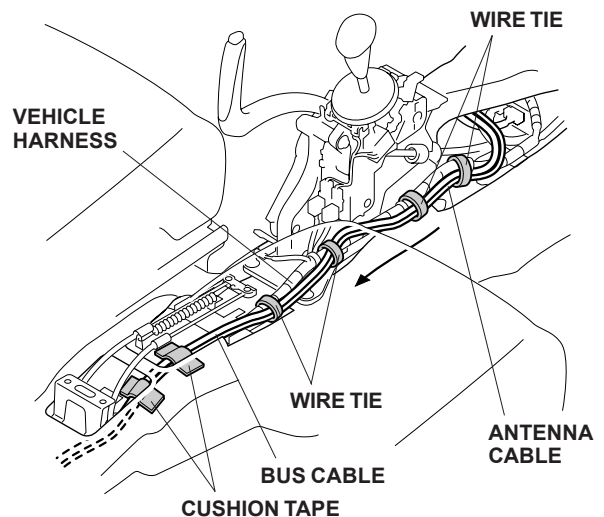

44. Using isopropyl alcohol on a shop towel, clean the area where the cushion tape will attach. Attach the Bus cable and antenna cable to the floor panel with two cushion tapes in the area shown.

45. Pull back the carpet. Route the antenna cable along the Bus cable, then attach the Bus cable and antenna cable to the floor panel with two cushion tapes in the areas shown.

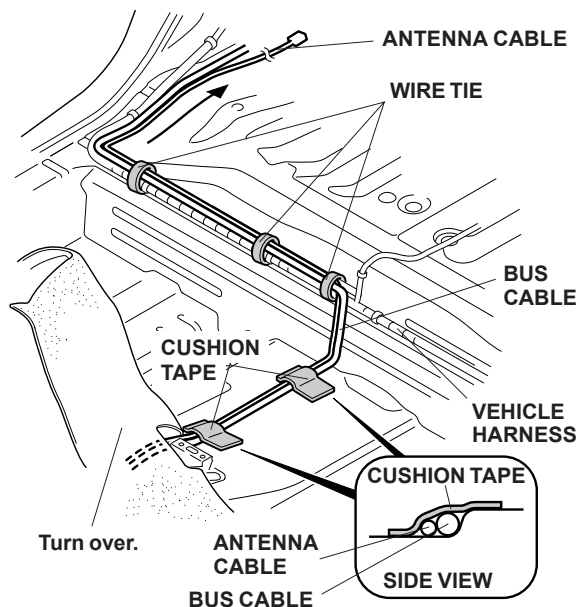

46. Secure the Bus cable and antenna cable to the vehicle harness with three wire ties in the areas shown.
47. Route the antenna cable along the Bus cable. Secure the Bus cable and antenna cable to the vehicle harness with two wire ties in the areas shown.

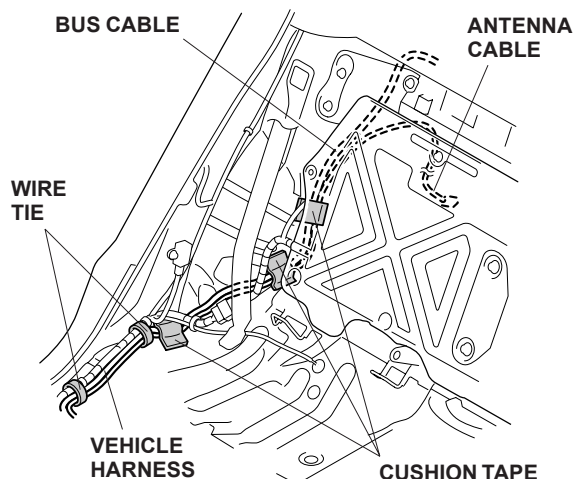

48. Attach the Bus cable and antenna cable to the floor panel with three cushion tapes in the areas shown.

### Installing the XM Radio Unit

49. Using four pan screws and four washers, install the front and rear brackets to the XM radio unit.

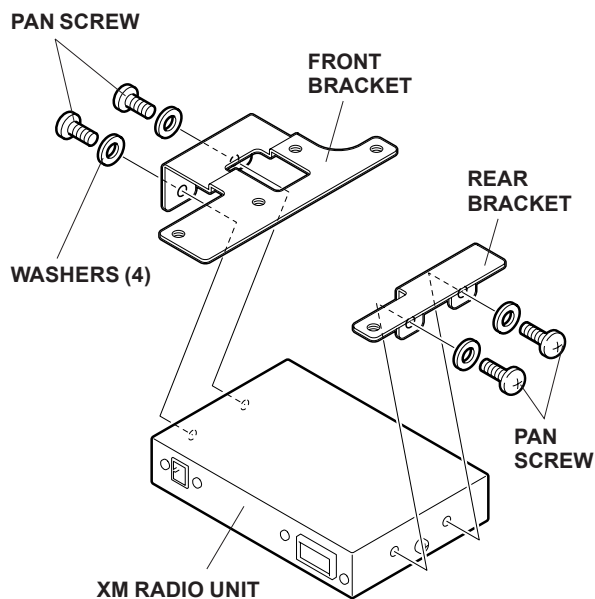

50. Using isopropyl alcohol on a shop towel, clean the trunk right inner panel in the area shown. Attach one EPT sealer to the trunk right panel as shown.

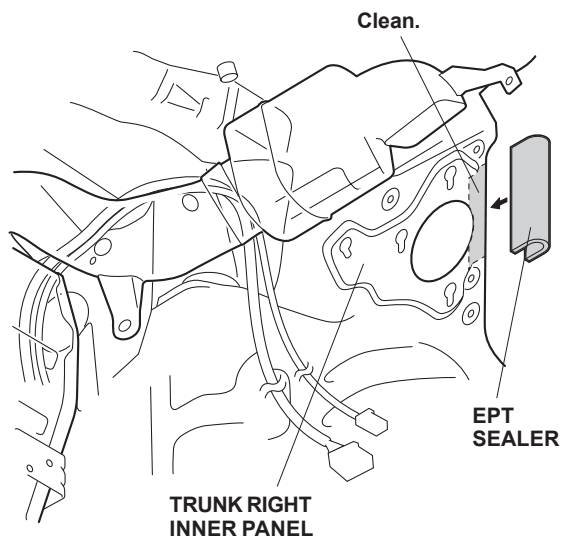

51. Plug the Bus cable connector and the antenna cable connector into the XM radio unit.

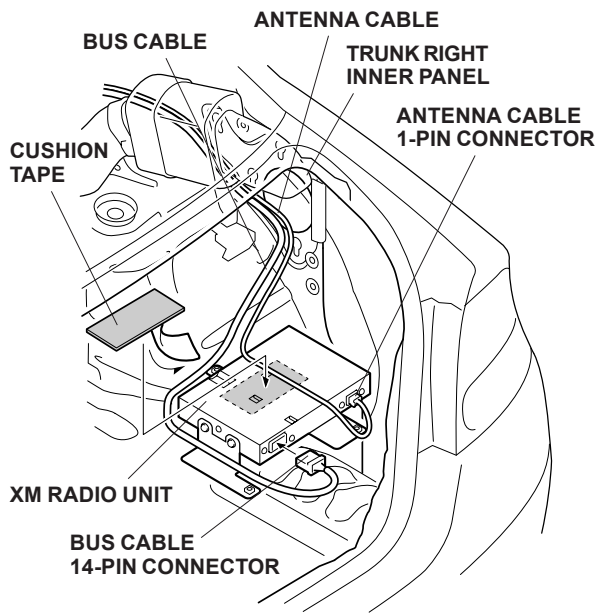

52. Using isopropyl alcohol on a shop towel, clean the area shown on the XM radio unit where the cushion tape will attach. Using one cushion tape, secure the antenna cable to the XM radio unit.

53. Loosely install three flange bolts to the front and rear brackets. On the front bracket, use the "A"-marked holes.

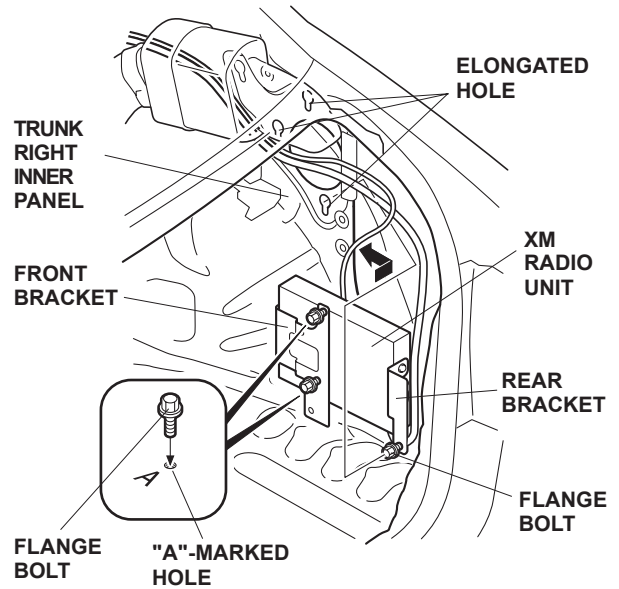

54. Place the XM radio assembly on the back of the trunk right inner panel. Set the three flange bolts into the elongated holes in the inner panel. Tighten the three flange bolts securely.

55. Using three wire ties with clips, secure the bus and antenna cables in the areas shown.

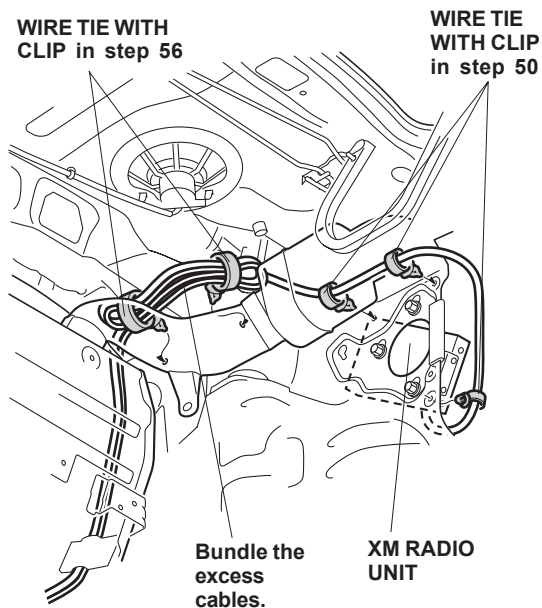

56. Using two wire ties with clips, bundle the excess of the bus and antenna cables to the holes on the right trunk inner panel.

***If the vehicle you're working on is equipped with a CD Changer, go to step 57; otherwise, go to step 59.***

57. Plug the 2-port bus cable connectors in the two bus cables.

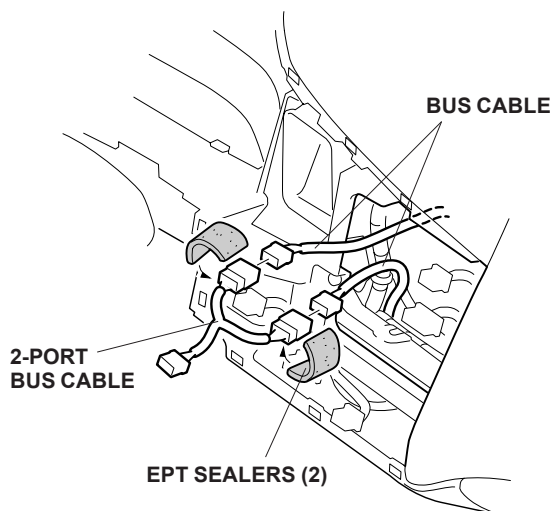

58. Wrap the two plugged connectors using two EPT sealers.

59. Plug the bus cable connector into the audio unit or the navigation system unit.

#### Audio Unit

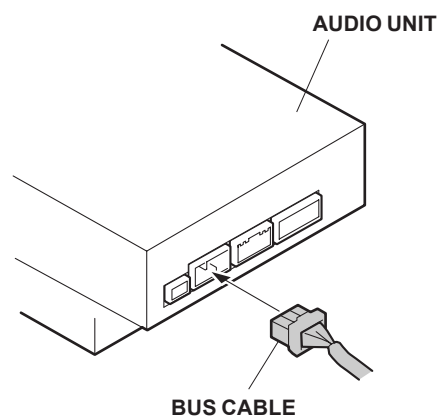

#### Navigation Unit

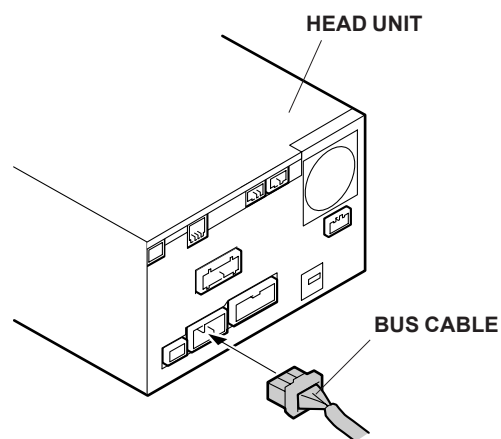

60. Connect the vehicle connectors to the center panel, and reinstall the center panel.

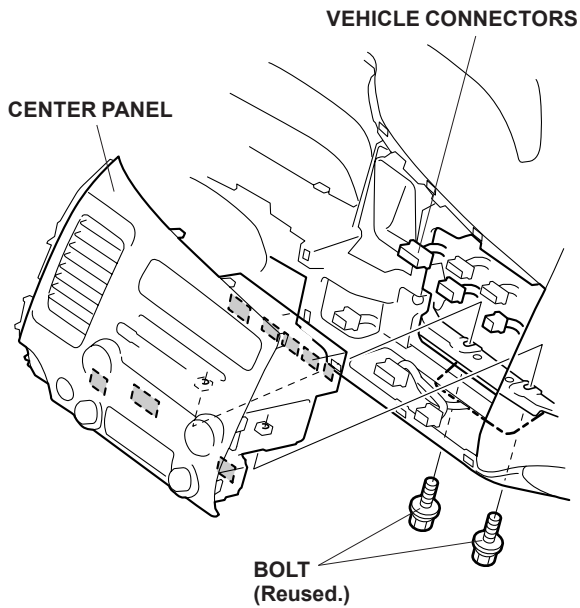

61. Replace the clip on the right front pillar trim with a new one.

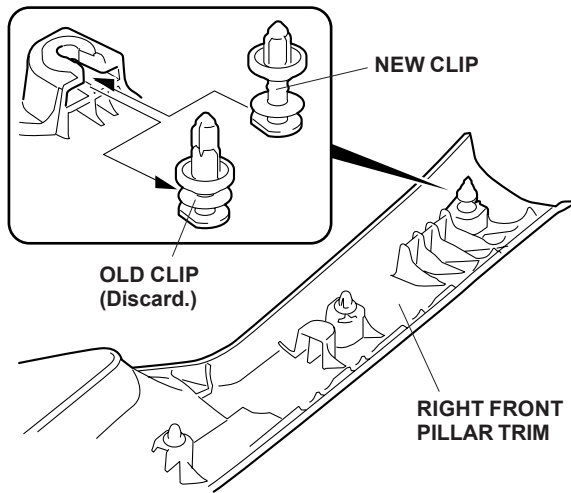

62. Check that all wire harnesses are routed properly and all connectors are plugged in.
63. Reconnect the negative cable to the battery.
64. Enter the customer's radio anti-theft code, and reset the radio station presets.
65. Set the clock.
66. Check the operation of the XM radio system according to the vehicle's Owner's Manual.
67. Reinstall all removed parts.
68. If the IMA battery level gauge (BAT) displays zero segments, start the engine, and hold it between 3,500 and 4,000 rpm (in Park or Neutral) until the IMA level gauge (BAT) displays full segments.